

SUBARU

Part number

L105ESC000

Model name :Forester
 Model year :2008 →
 Body :All
 Model serie :SH
 Car homologation nr. :e13*2001/116*0982*..
 Max. car weight :2045 kg
 Max. towing weight :2000 kg
 Max. vertical weight :80 kg
 D-value :9,92 kN
 Type nr. :38.8183
 Towbar EEC approval nr. :e4*94/20*3675*00

- (GB) Fitting instruction for :Towbar
- (D) Einbauanleitung für :Anhängerkupplung
- (F) Instructions de montage pour :Attelage
- (NL) Inbouwhandleiding voor :Trekhaak
- (E) Instrucciones de montaje para :Gancho de remolque
- (S) Monteringsanvisning :Dragkrok
- (I) Istruzioni per il montaggio per :Gancio di traino

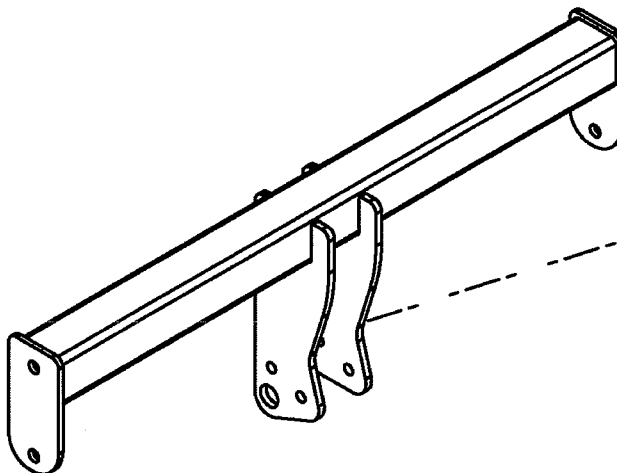
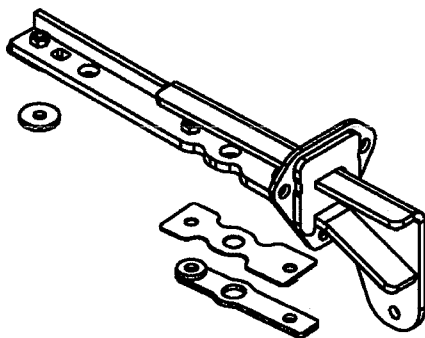
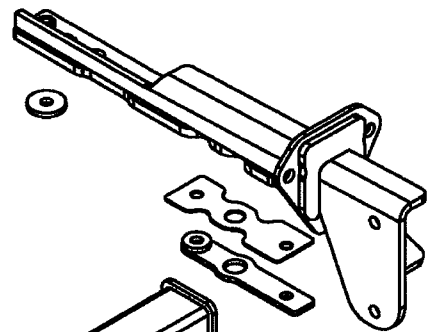
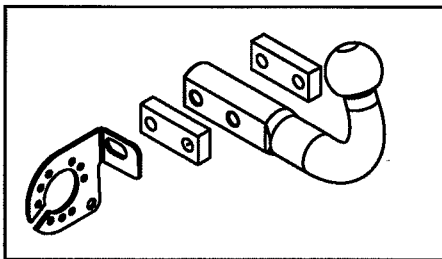

SUBARU

Forester
 2008-
 P/No L105ESC000
 38.8183
 Ser no

e4

00 3675
 Class A50-x
 R= 2000 kg
 S= 80 kg
 D= 9,92 kN

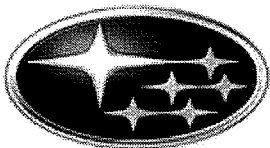

SUBARU

Part number

L105ESC000

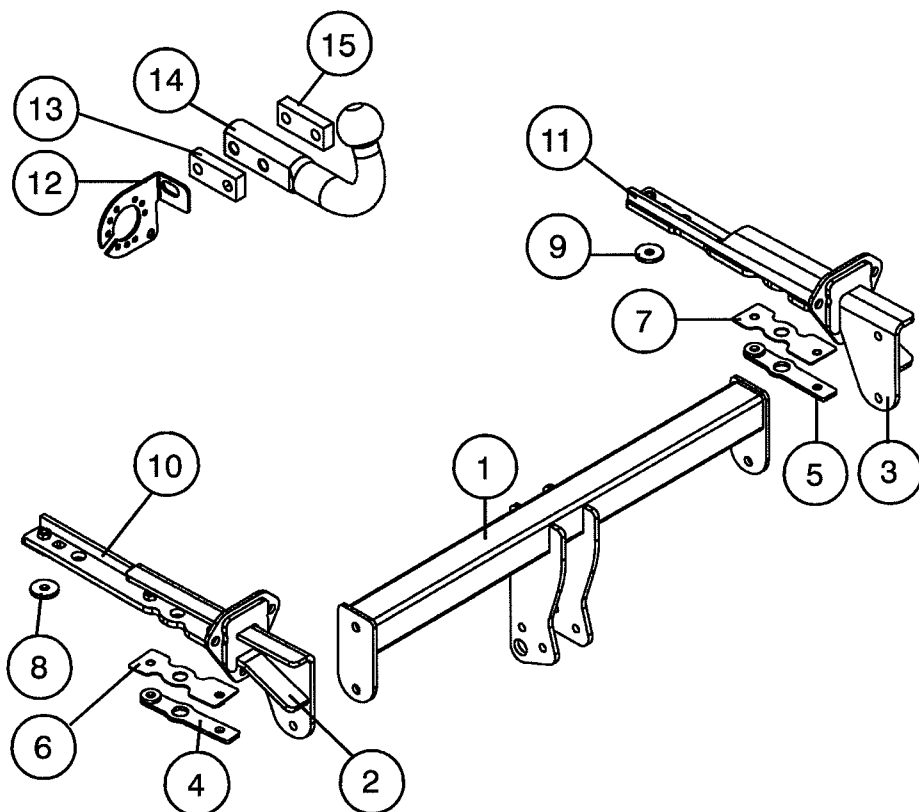

	6x	M10x40(10.9)
	4x	M12x40(10.9)
	2x	M12x100(8.8)
	6x	M10
	2x	M12
	6x	M10
	7x	M12
	4x	M12
	6x	M10

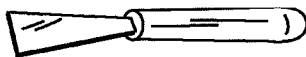
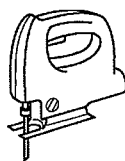
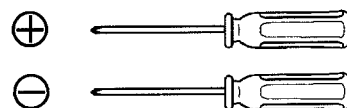
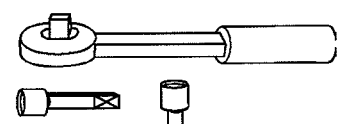

GB

Read this mounting manual carefully, before you start the installation. Warranty is granted only when installation is done correctly by your Subaru dealer. Modification related to design, construction, illustrations and text are reserved.

D

Lesen Sie sich, bevor Sie zur Montage schreiten, diese Montageanleitung aufmerksam durch. Es wird nur eine Garantie gewährt, wenn die Installation von einem anerkannten Subaru-Händler richtig ausgeführt wird. Veränderungen hinsichtlich Entwurf, Konstruktion, Abbildung und Text sind vorbehalten.

F

Lire attentivement ces instructions de montage avant de procéder à l'installation. La garantie n'est valable que si l'installation est réalisée correctement par un concessionnaire agréé Subaru. Sous réserve de modifications apportées au concept, à la construction, à l'illustration et au texte.

NL

Lees deze montagehandleiding zorgvuldig door, alvorens U tot installatie overgaat. Garantie wordt alleen verleend indien de installatie correct is uitgevoerd door een erkende Subaru dealer. Veranderingen ten aanzien van ontwerp, constructie, afbeelding en tekst zijn voorbehouden.

E

Léanse cuidadosamente estas instrucciones de montaje, antes de proceder a la instalación. Únicamente se da garantía si la instalación ha sido correctamente realizada por un concesionario oficial Subaru. Sujeto a modificaciones con respecto a diseño, construcción, representación y texto.

S

Läs noga igenom denna monteringsanvisning innan installationen påbörjas. Garanti ges endast om installationen har utförts korrekt av en auktoriserad Subaru-försäljare. Rätt till ändringar i design, konstruktion, bilder och text förbehålls.

I

Leggere attentamente queste istruzioni per il montaggio prima di iniziare l'installazione. La garanzia è valida solo se l'installazione viene correttamente eseguita da un rivenditore autorizzato Subaru. Si riserva l'eventualità di apportare modifiche al disegno, alla costruzione, all'immagine e al testo.

Part number
L105ESC000

Issue
01

Date
01/02-2008

Subaru Europe

Page 02

01

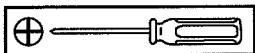
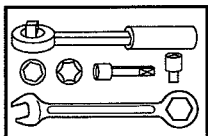
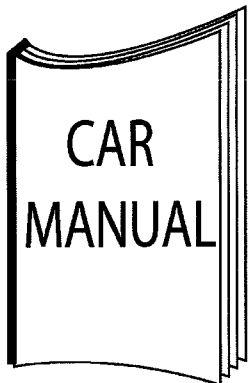
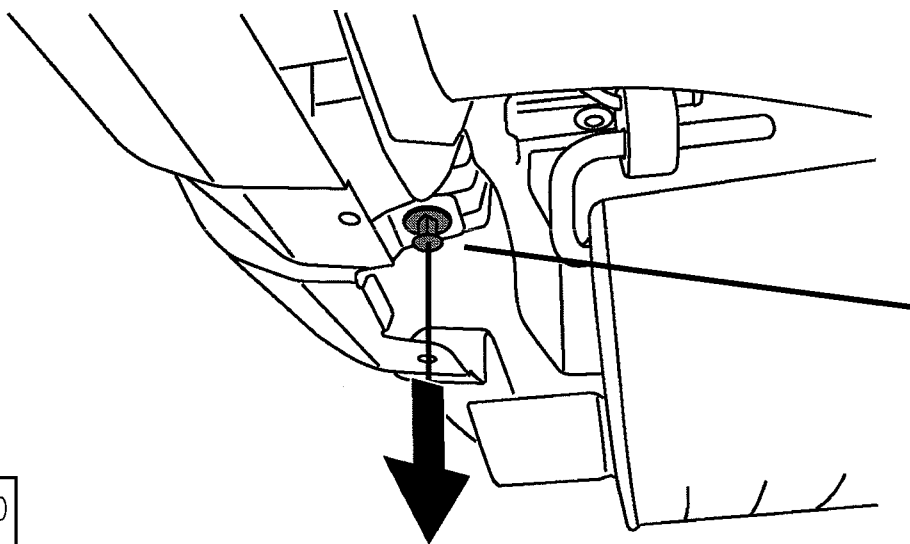
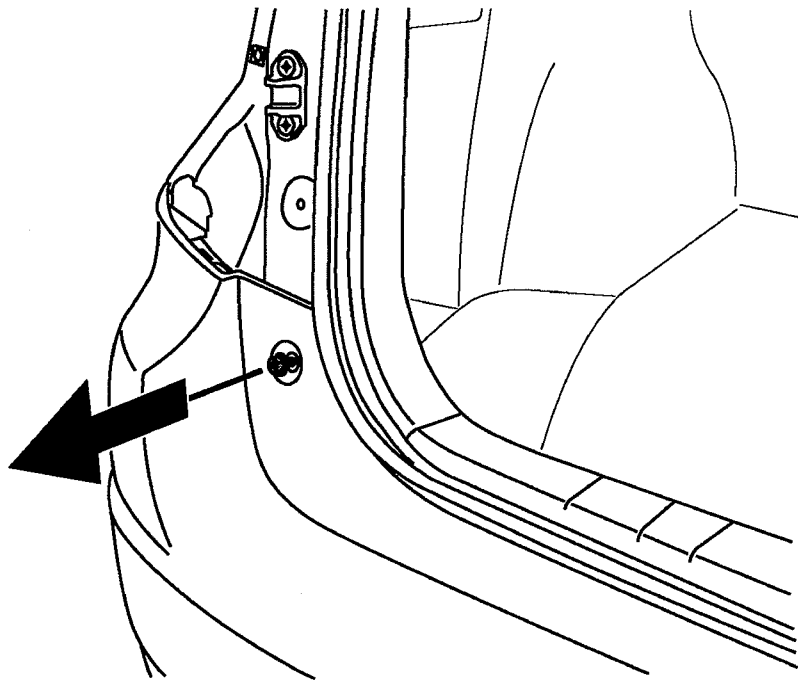
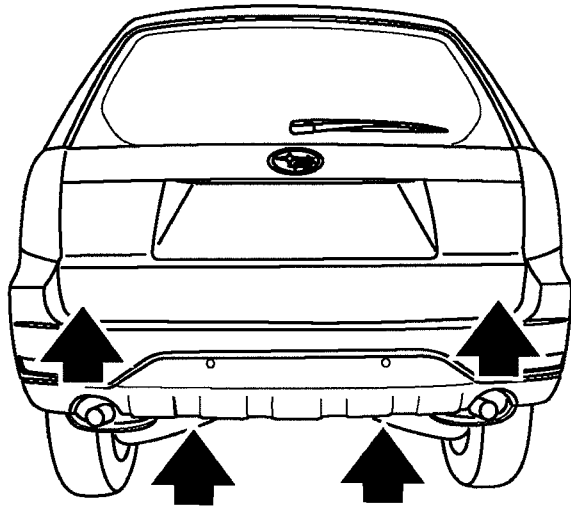

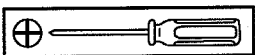
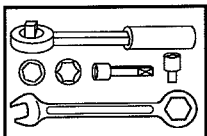
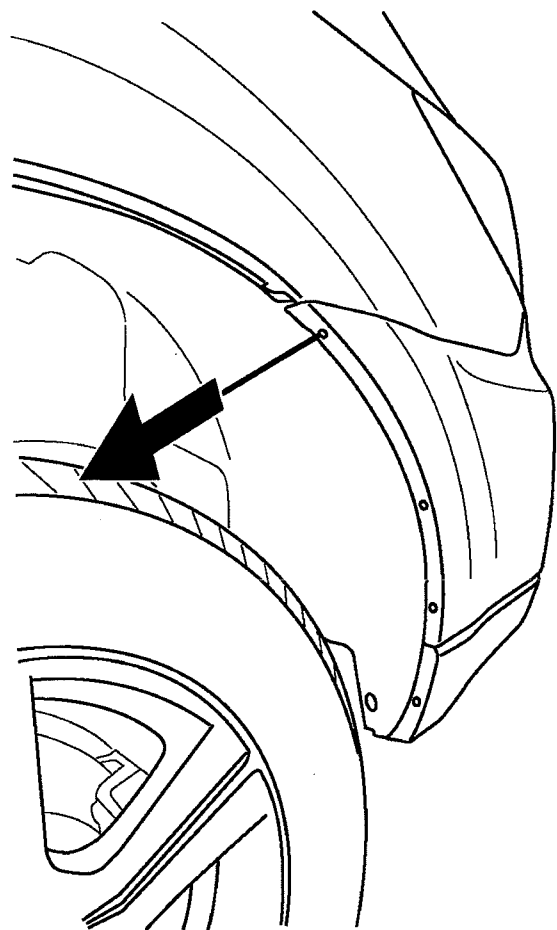
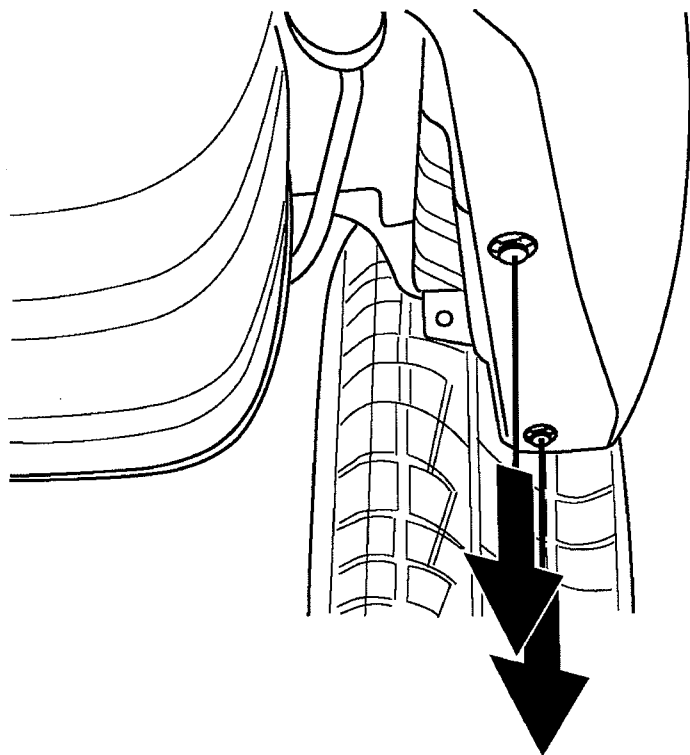
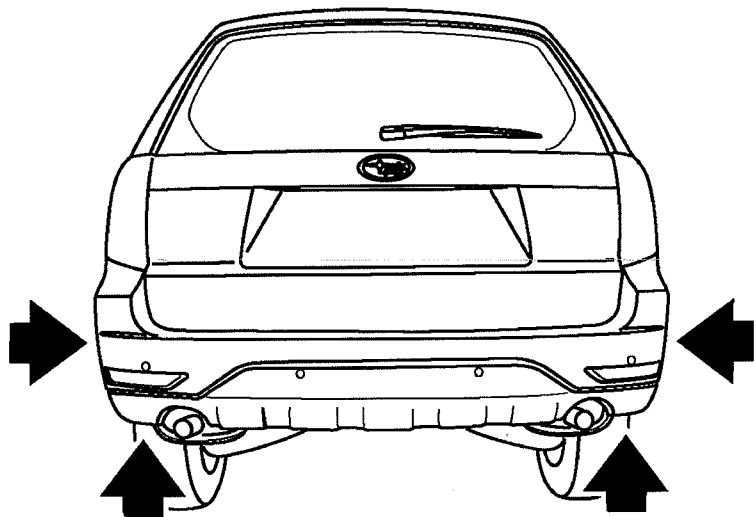

03

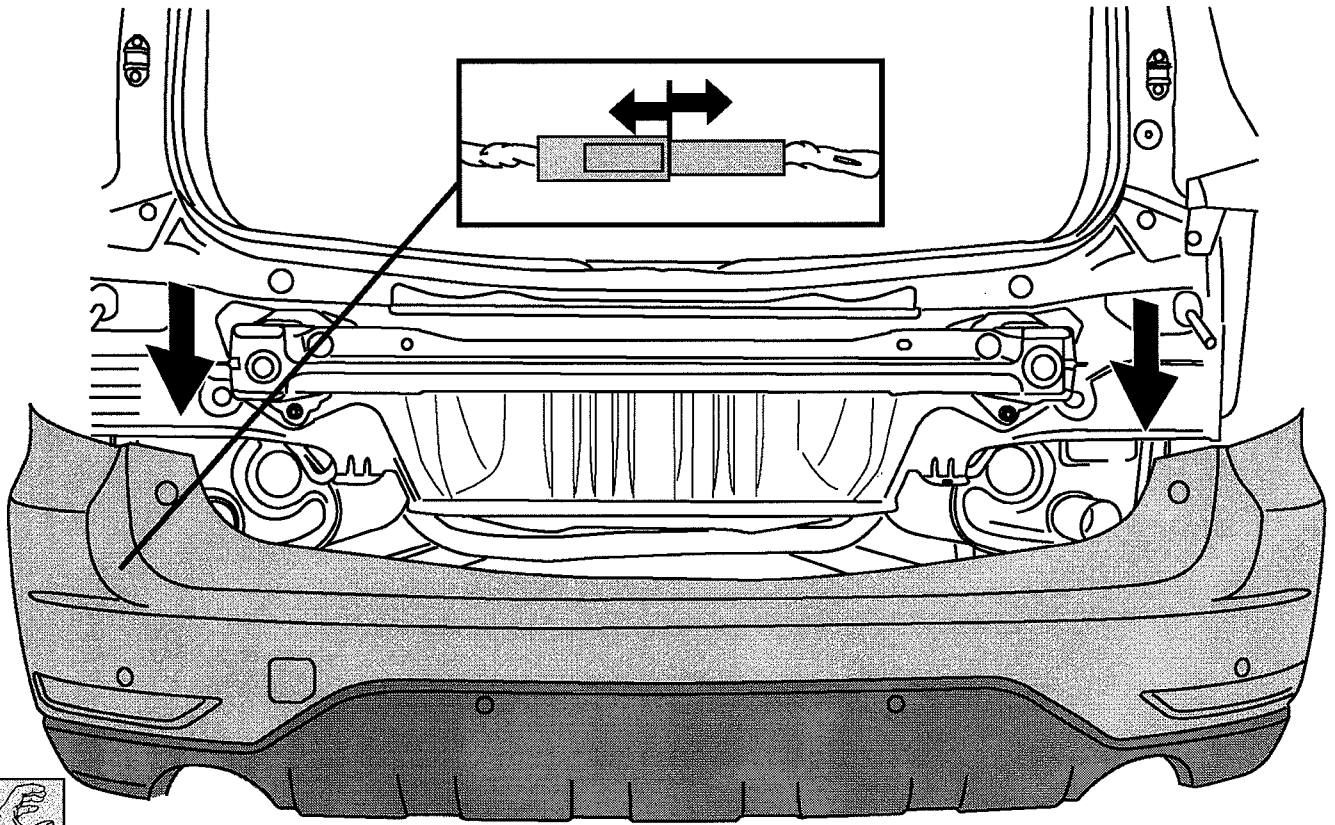

04a

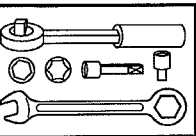
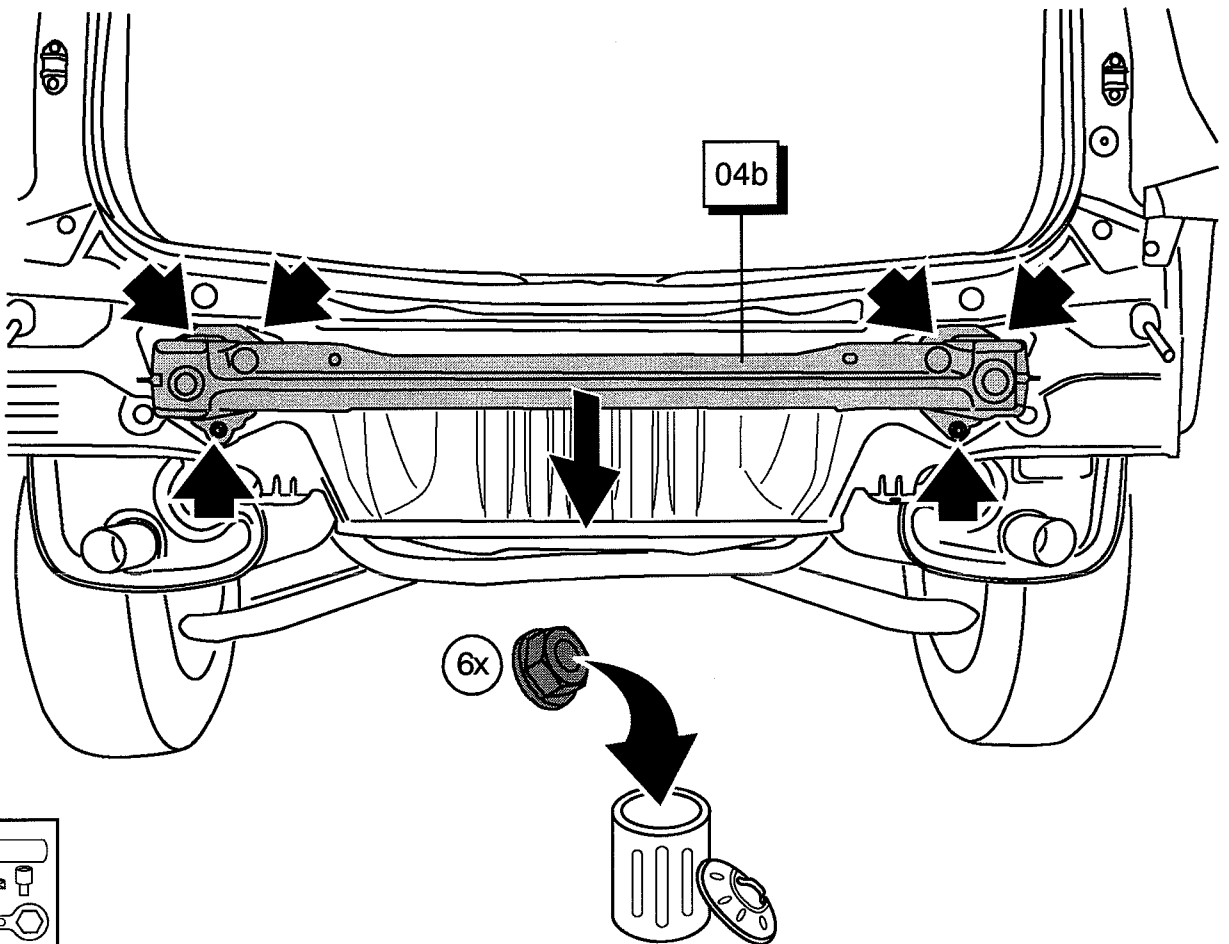

04b

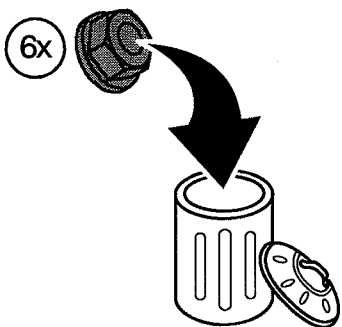

04b

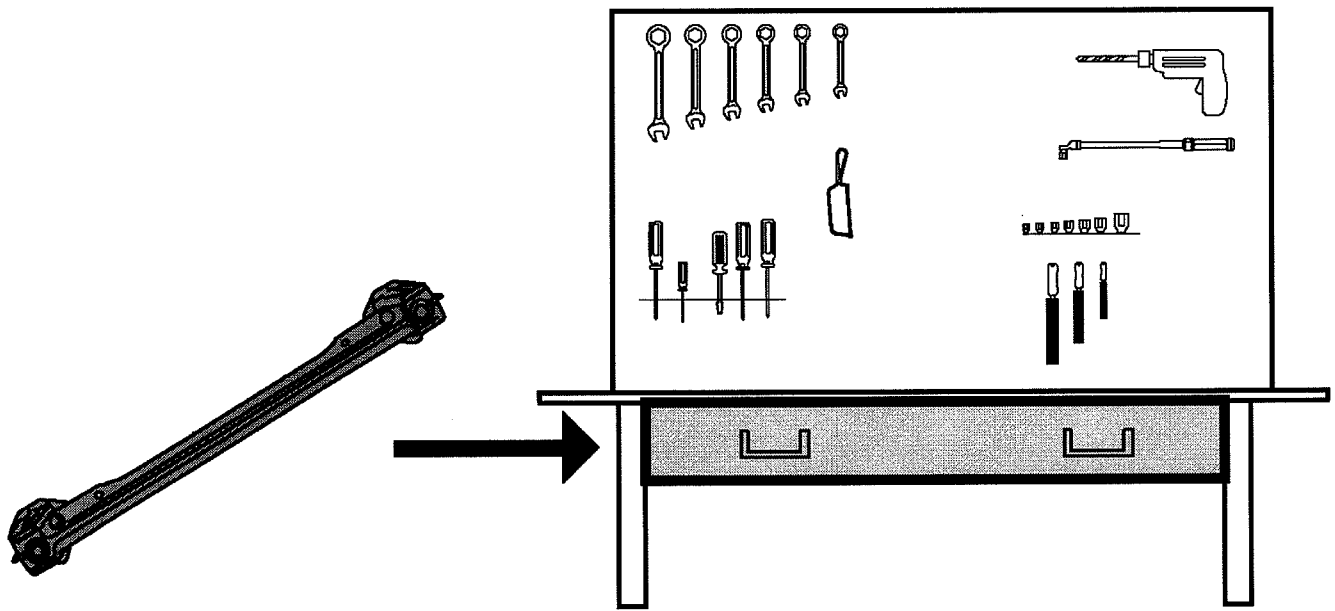

05

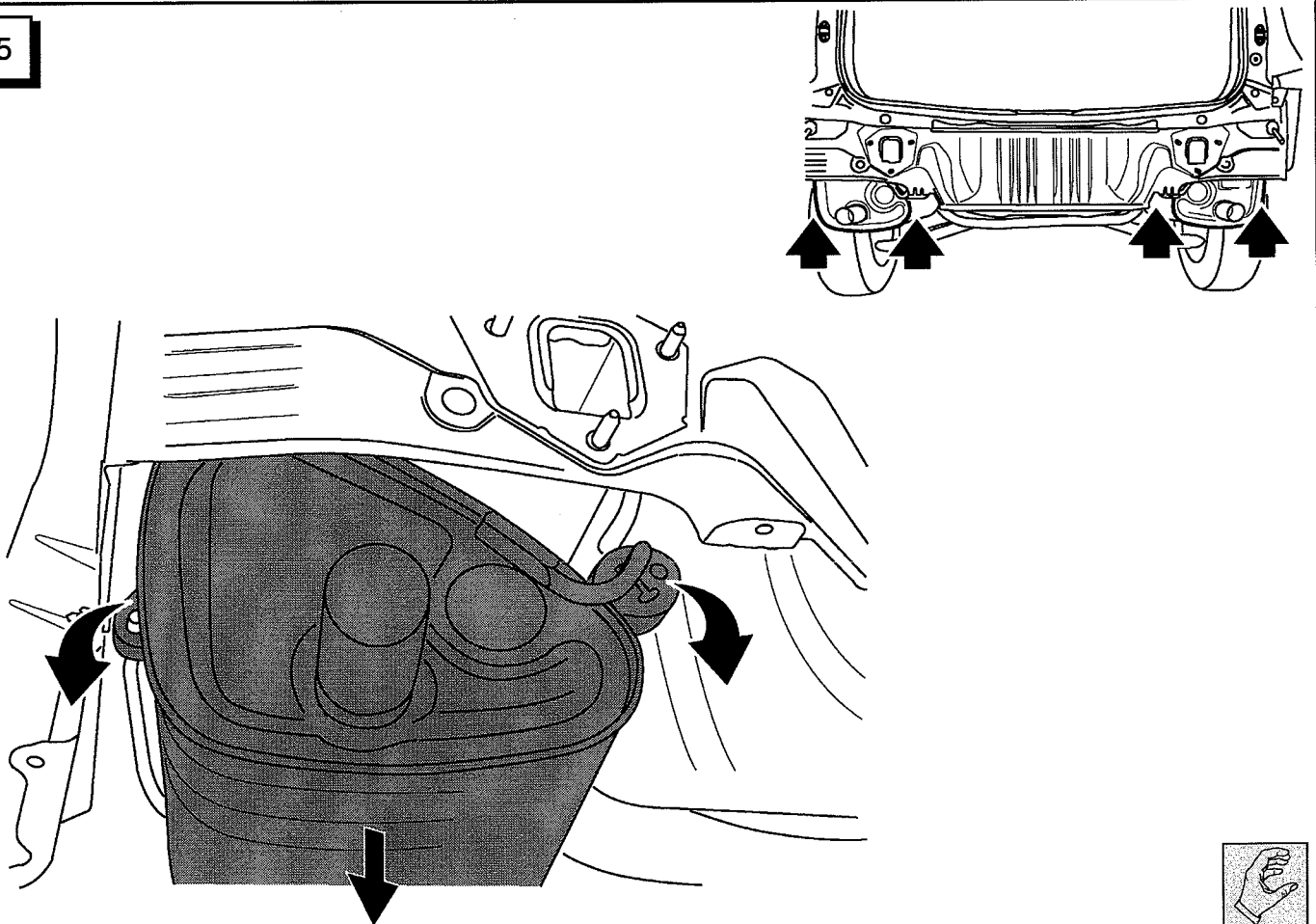

06a

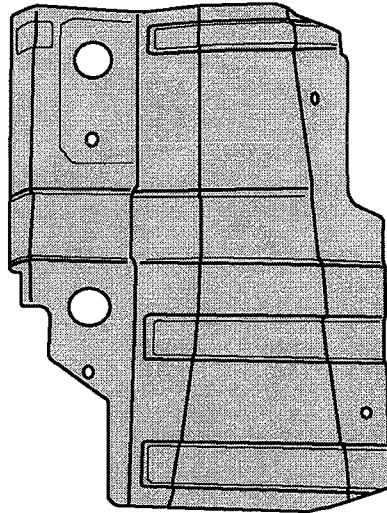
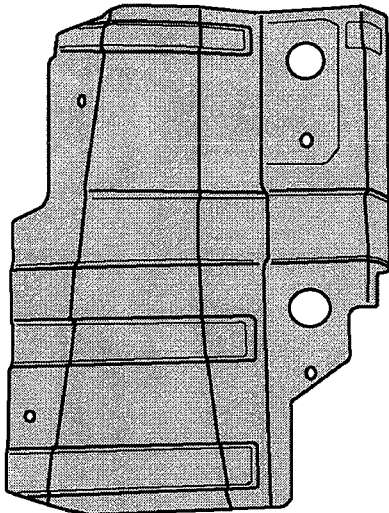
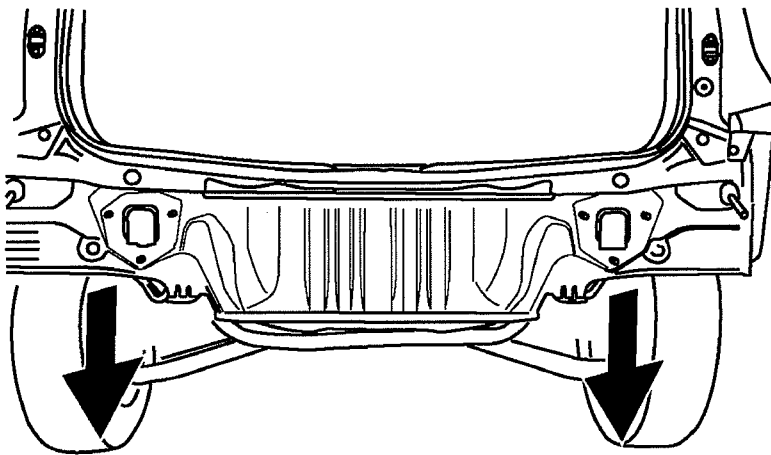
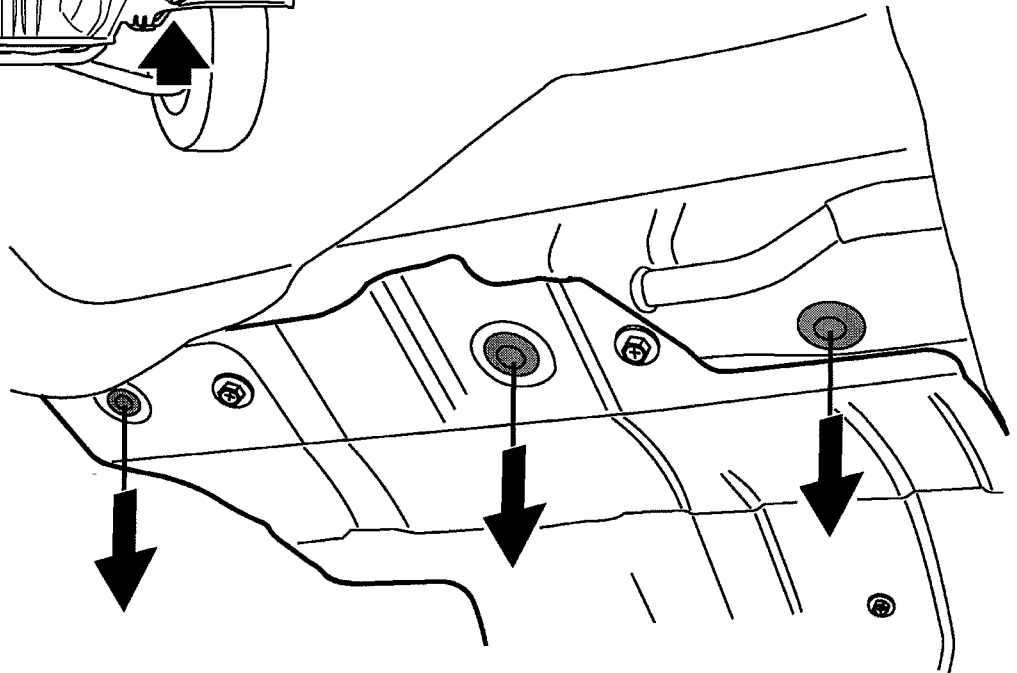
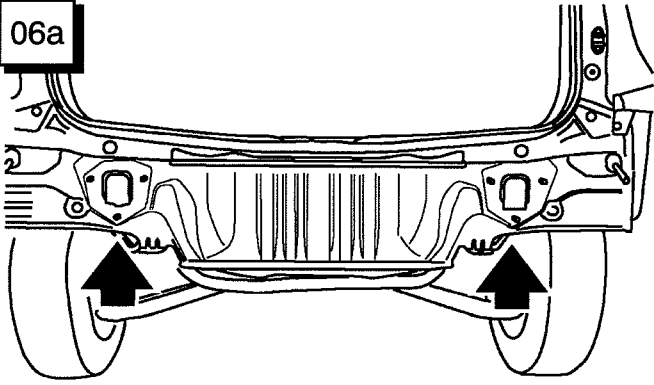

06b

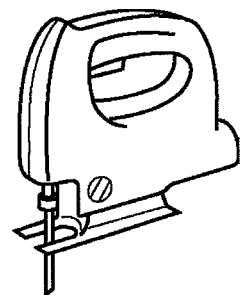
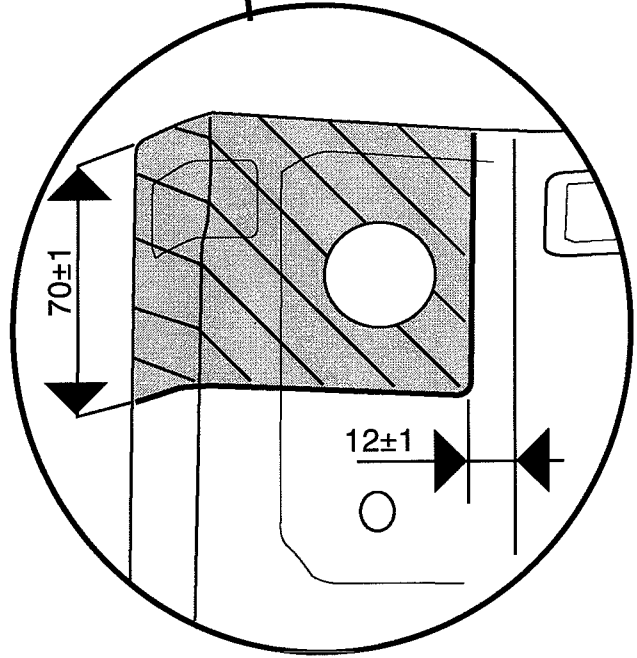
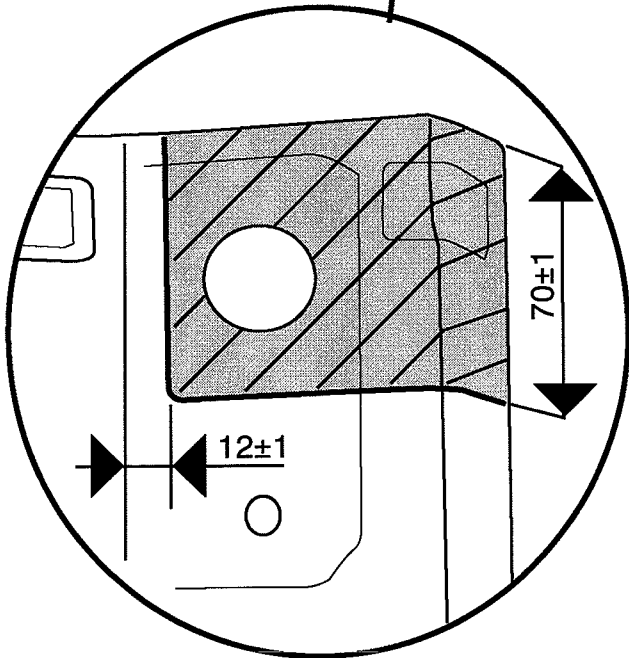
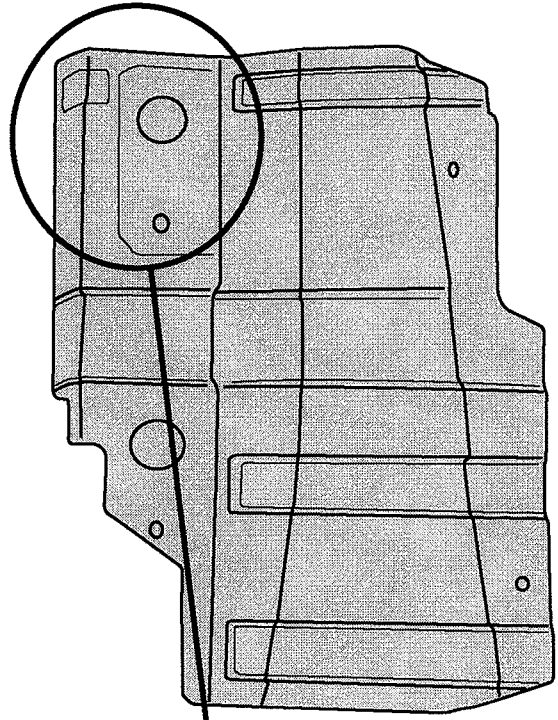
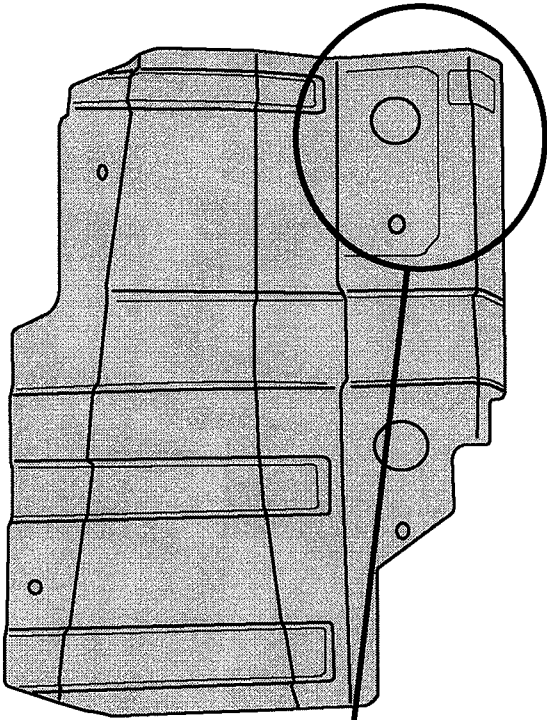

06c

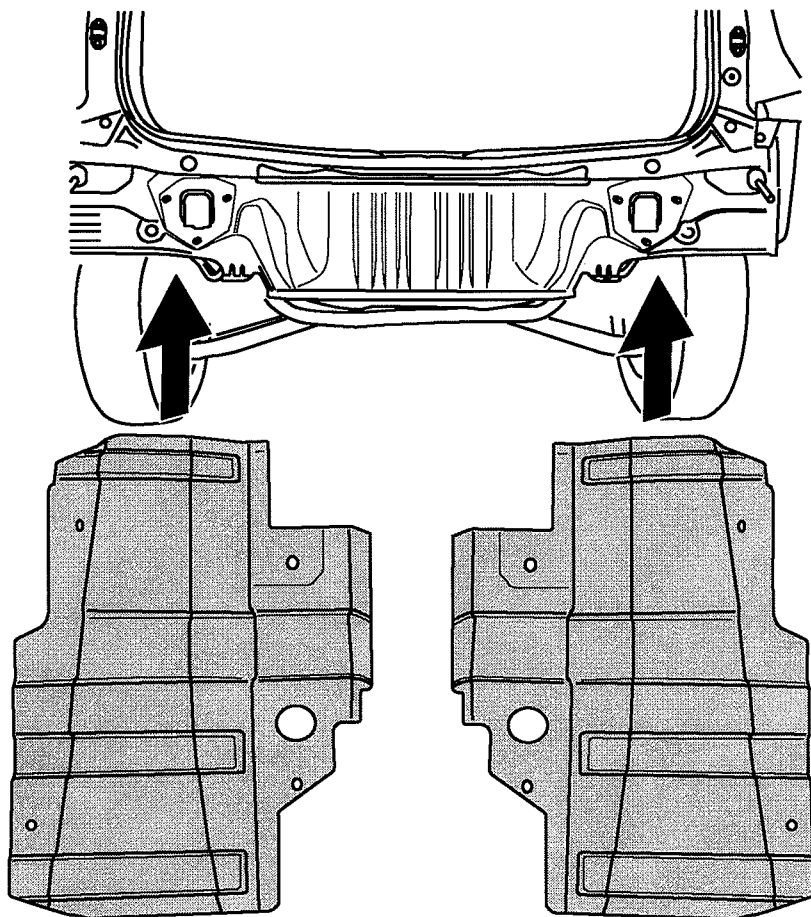
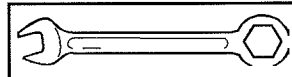

07

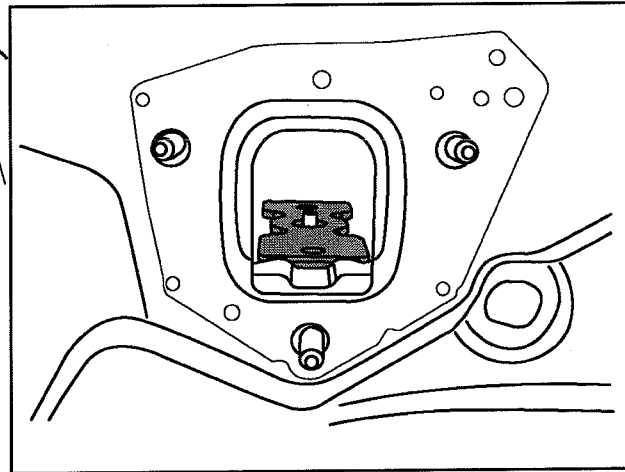
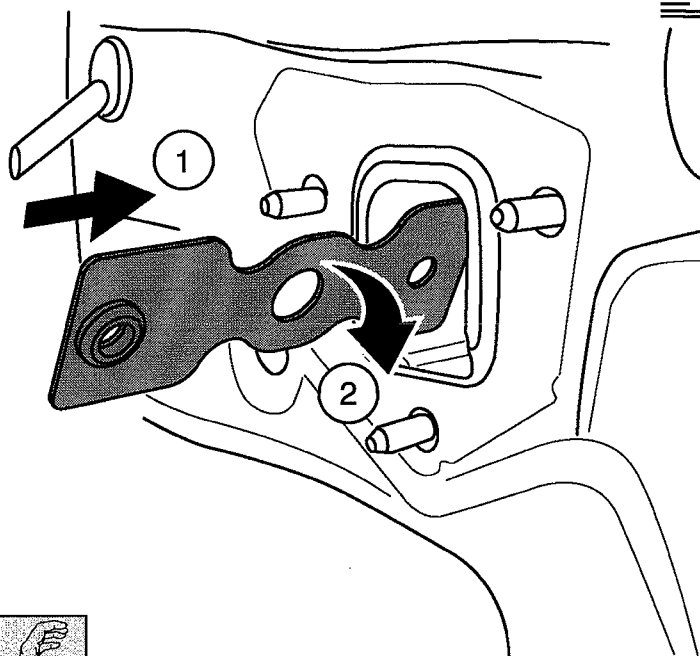
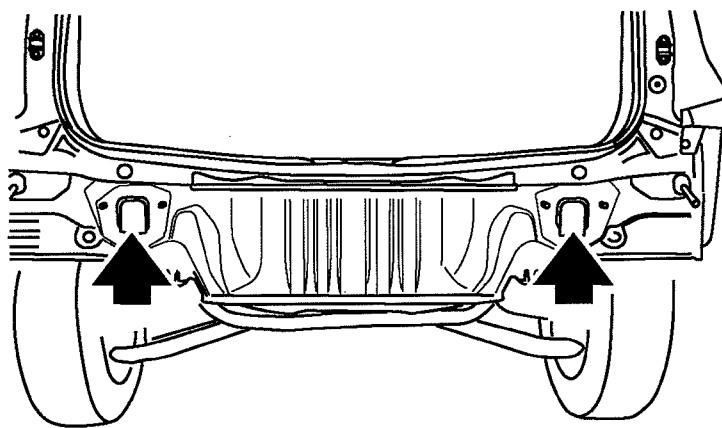

08a

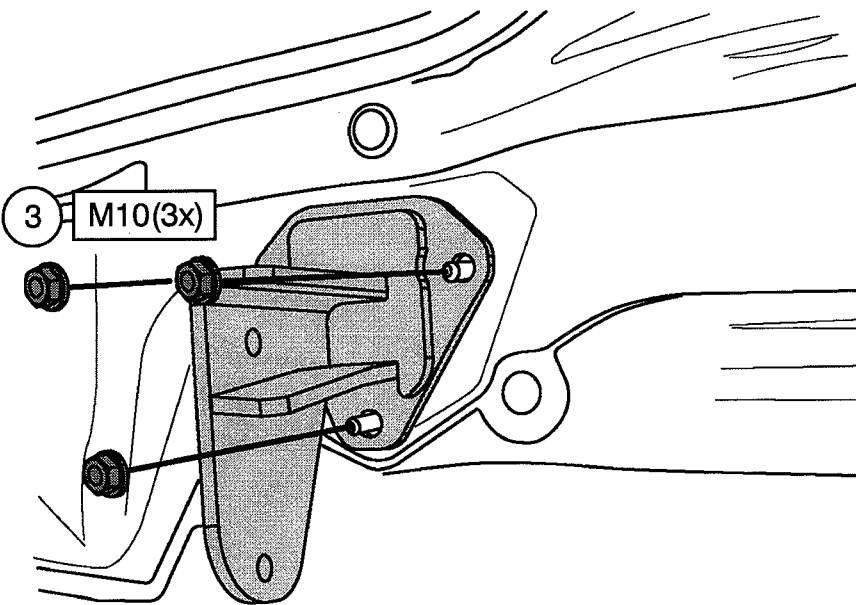
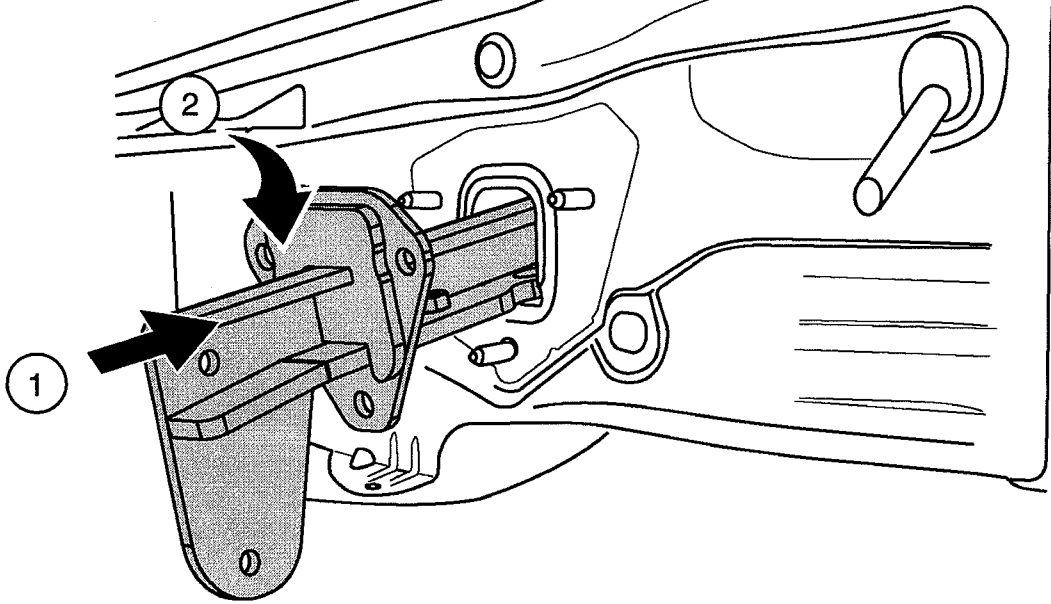
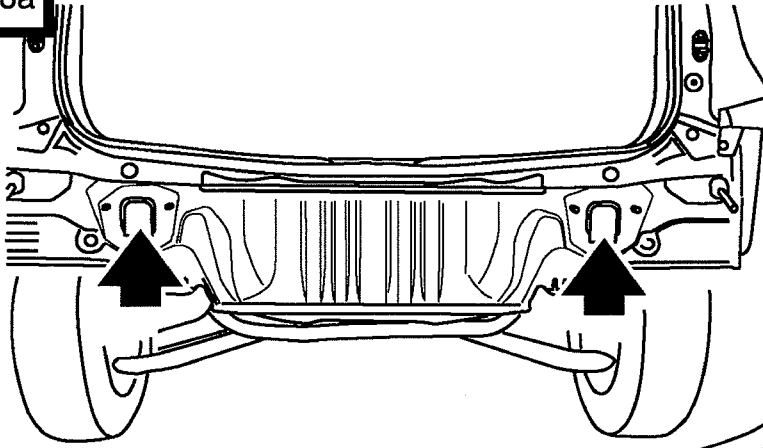

08b

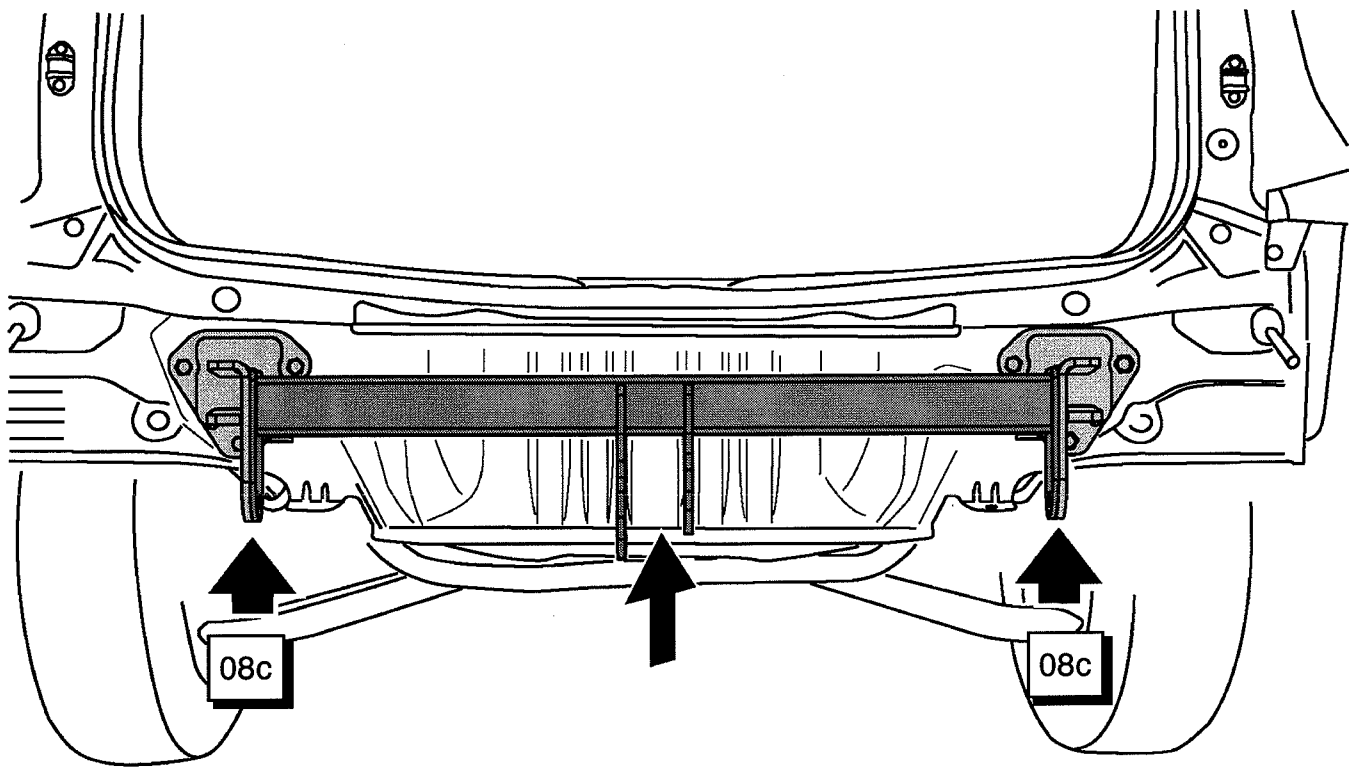
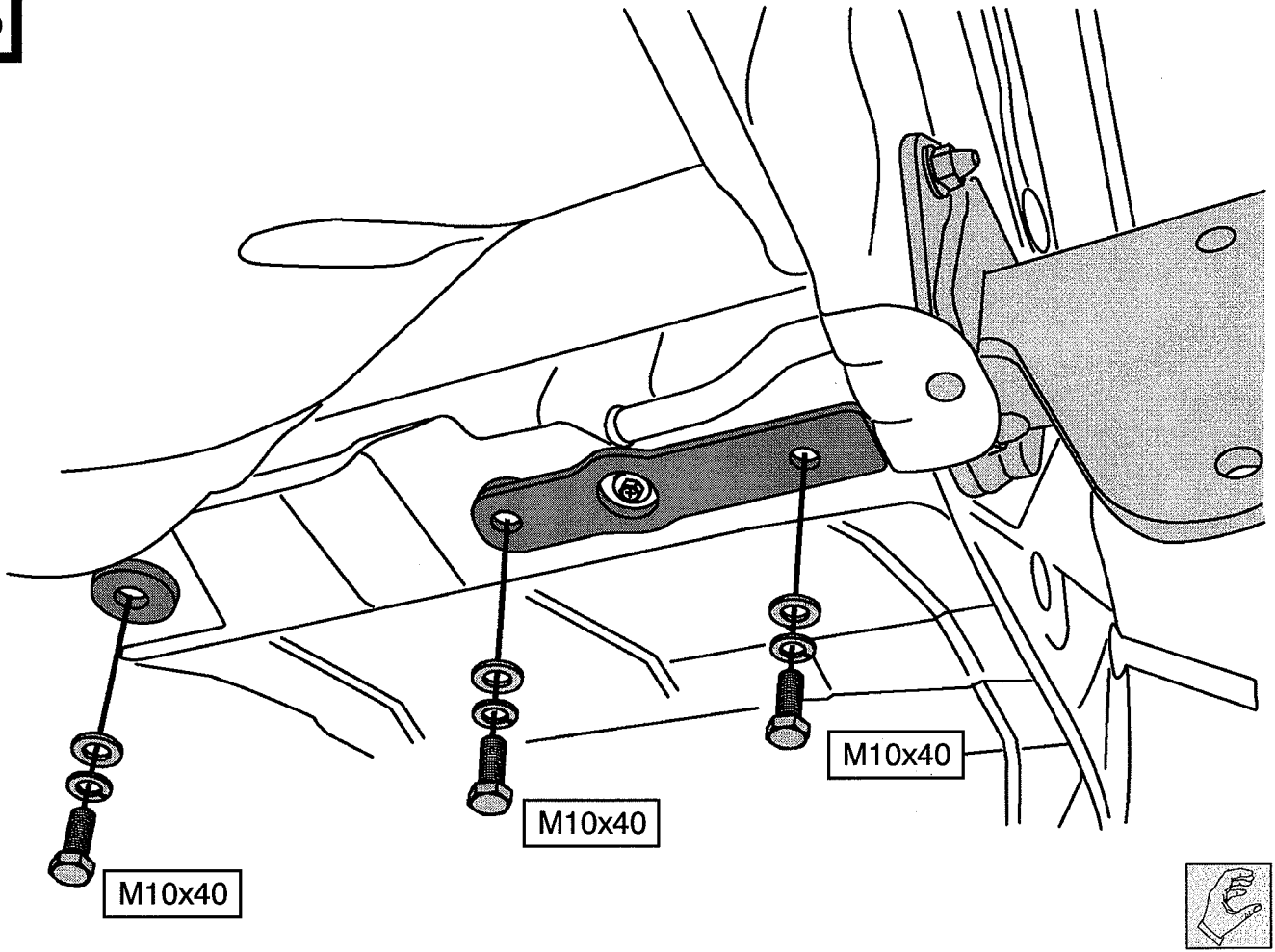

08c

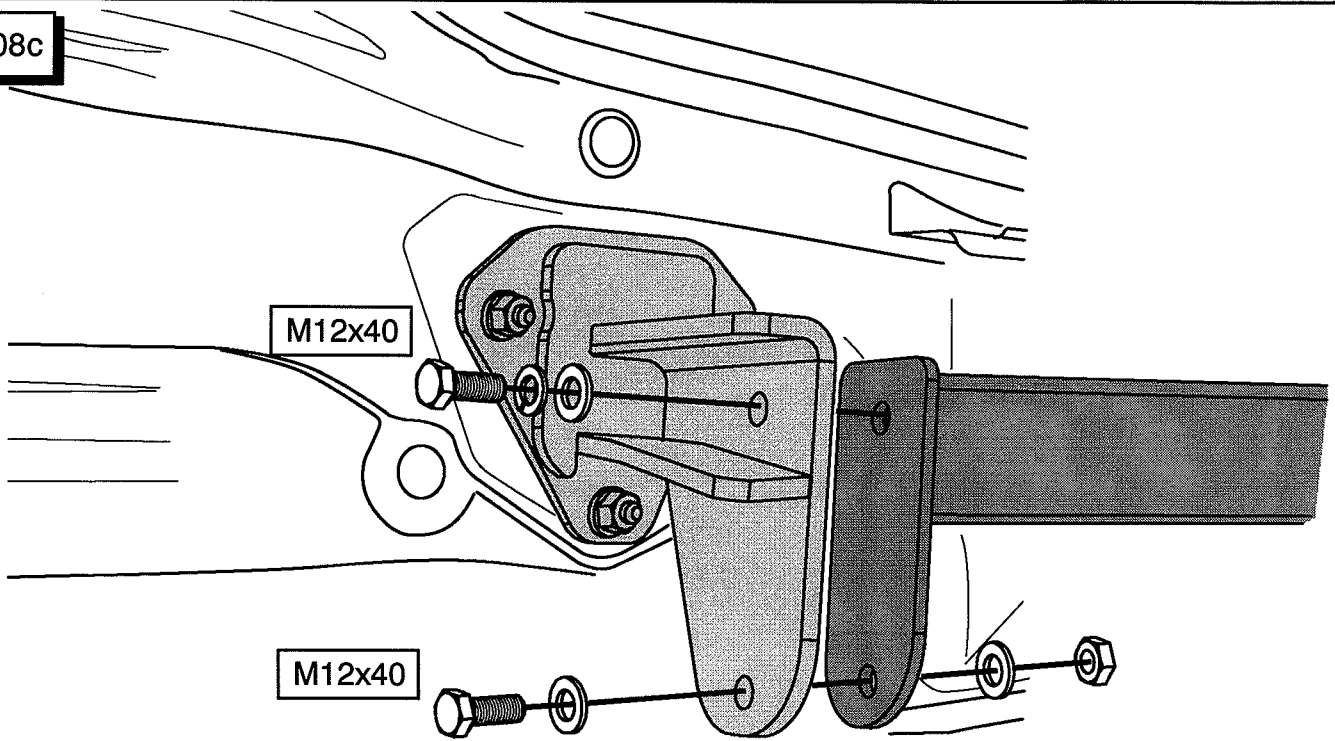

	Screw/Nm	M12	X
	Class 10.9	83	

	Screw/Nm	M10	X
	Class 10.9	63	

	Screw/Nm	M10	X
		50	

	Screw/Nm	M10	X
		50	

	Screw/Nm	M12	X
	Class 10.9	83	

	Screw/Nm	M10	X
	Class 10.9	63	

09

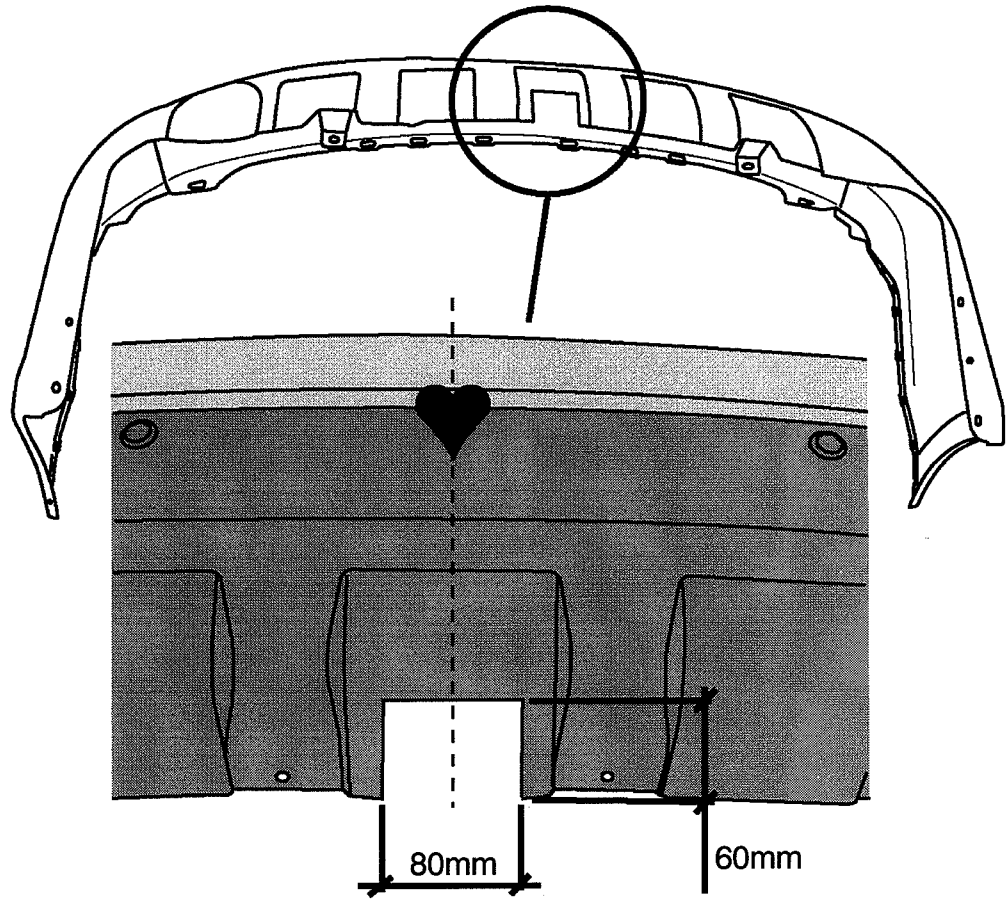

10

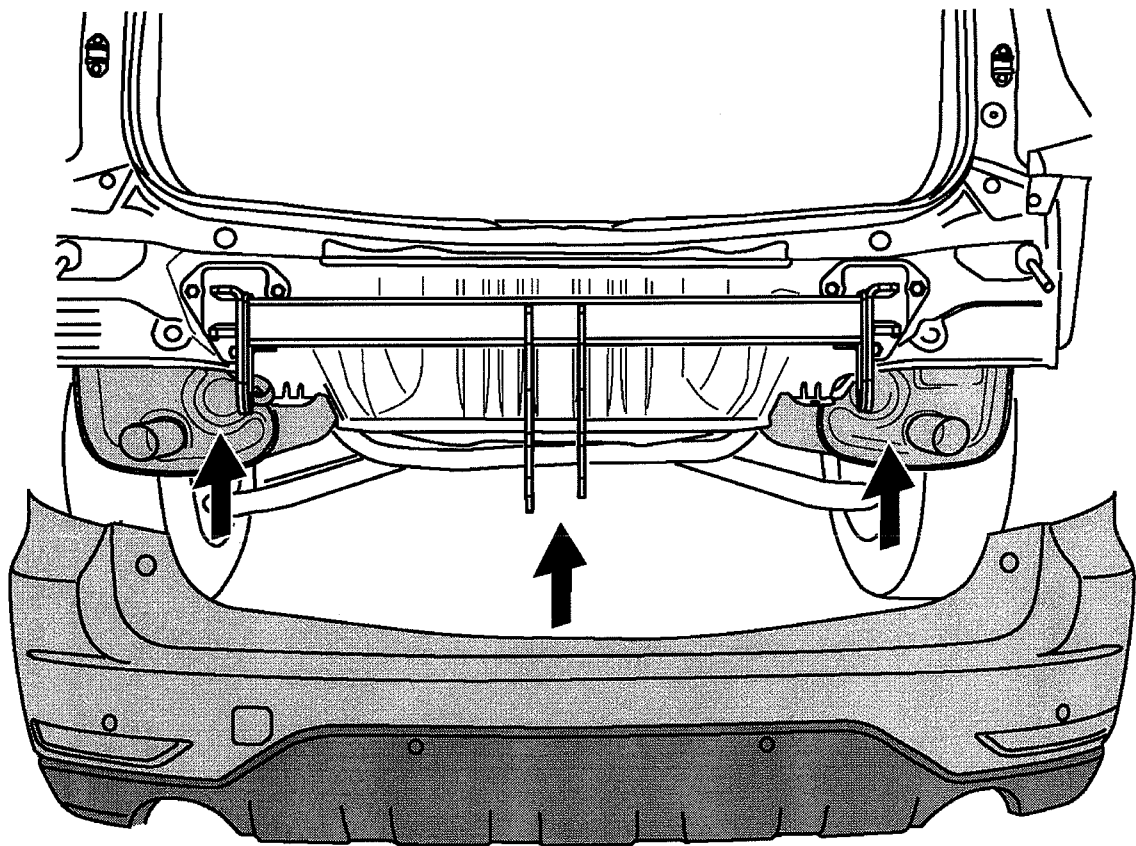

11

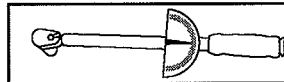
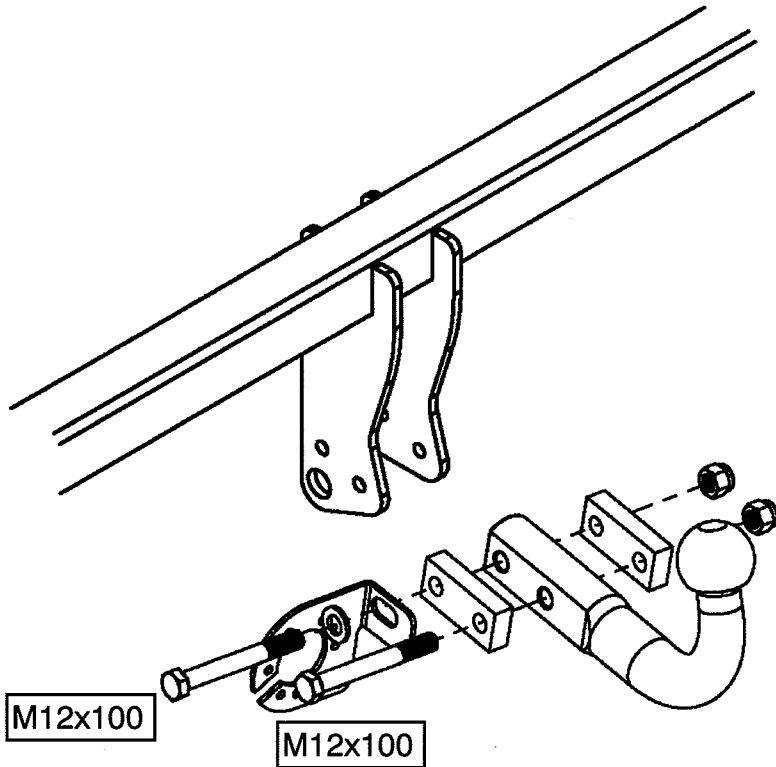

Screw/Nm	M12	
Class 8.8	83	

12

0 KM

1000 KM

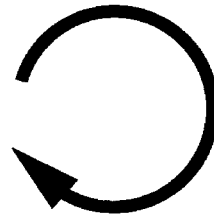
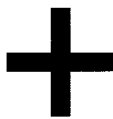
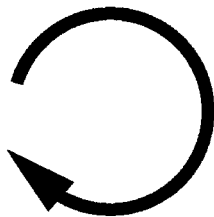
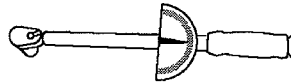
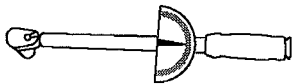

13

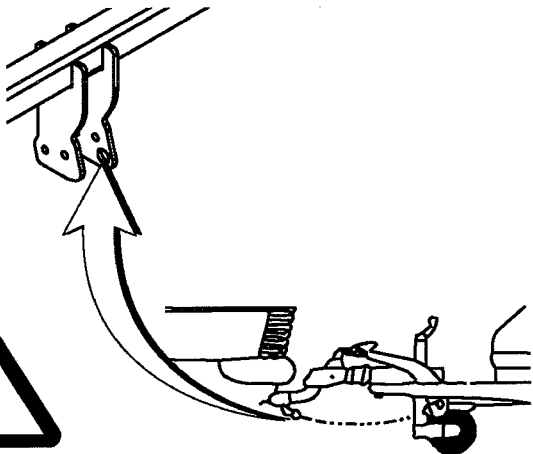

14

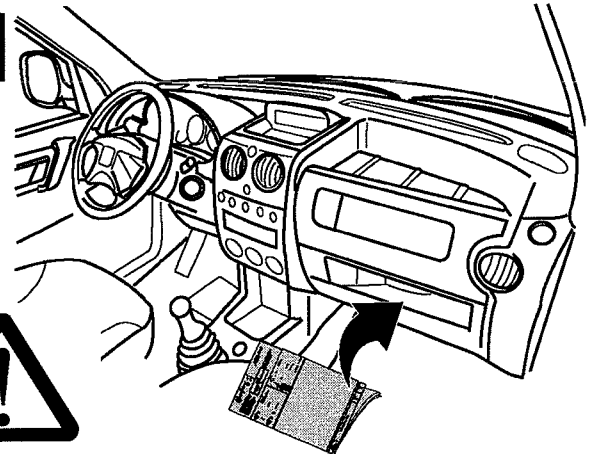

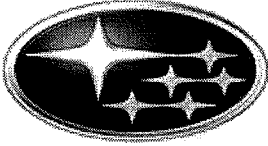

SUBARU

Part number

L105ESC000

(GB) NOTE:

- * Don't forget the spring- and plain washers ;
- * Please consult your car dealer, or owners manual for the max. permissible towing mass ;
- * After about 1000 km use, re-tighten the bolts and nuts to the specified torque ;
- * These fitting instructions should be considered a permanent part of the vehicle and should remain with the vehicle if sold ;
- * Monoflex (Monoflex APS / Monoflex AB) cannot be held responsible for any defects in the product caused by fault or by any injudicious use whatever of the user or a person he is liable for.

(D) HINWEISE:

- * Die Federringe und Unterlegscheiben nicht vergessen ;
- * Alle Befestigungsschrauben nach ca. 1000 km Anhängerbetrieb nachziehen ;
- * Die Kupplungskugel ist sauber zu halten und zu fetten ;
- * Die für das Fahrzeug zugelassene Anhängelast ist den Fahrzeug Unterlagen zu entnehmen. Bei Änderungen des Fahrzeuggewichtes muß die höchstzulässige Anhängelast gegebenenfalls aus dem D-Wert nachgerechnet werden. Auskunft hierüber kann ihr Fachhändler oder der TÜV geben ;
- * Elektrische Anlage gemäß StVZO anbringen ;
- * Diese Anhängenzugvorrichtung ist nach der neuen Richtlinie EEC 94/20 geprüft worden. Gemäß dieser Richtlinie entfällt auch die Notwendigkeit, die Homologationsnummer direkt an der Anhängenzugvorrichtung zu markieren. Deshalb ist die Prüfnummer der Anhängenzugvorrichtung ausschließlich auf dem Typschild vermerkt ;
- * Diese Einbauanleitung ist eine offizielles Dokument, welches zu der Anhängenvorrichtung gehört und sorgfältig aufbewahrt werden sollte. Auch bei einem eventuellen Wiederverkauf des Fahrzeugs sollte die Einbauanleitung bei dem Fahrzeug verbleiben ;
- * Klebeschild mit Stützlastangabe am KfZ an gut sichtbarer Stelle in der Nähe der Kupplungskugel anbringen (Innenseite Kofferraum ist auch zulässig) ;
- * Für einen Mangel am Produkt, der durch den Fahrzeughalter oder eine andere Person aufgrund unsachgemäßer Benutzung verursacht wurde, übernimmt Monoflex (Monoflex APS / Monoflex AB) keine Haftung.

(F) REMARQUE:

- * Ne pas oublier les rondelles Grower et les rondelles de blocage ;
- * Pour le poids de traction maximum autorisé de votre voiture, consulter votre concessionnaire ;
- * Il est conseillé de vérifier le serrage de toute la boulonnerie après 1000 Km de traction ;
- * Ces instructions font partie du véhicule et doivent rester dans le véhicule lorsqu'il est vendu ;
- * Monoflex (Monoflex APS / Monoflex AB) décline toute responsabilité concernant des défauts éventuels de cet attelage qui seraient causés par une mauvaise utilisation. Seul l'utilisateur est responsable.

(NL) N.B.

- * Vergeet de veer- en sluitringen niet ;
- * Voor de max. toegestane massa, welke uw auto mag trekken, dient u uw dealer te raadplegen ;
- * Het is noodzakelijk om na ca. 1000 km gebruik de boutverbindingen na te trekken (volgens gegeven aanhaalmomenten) ;
- * Deze handleiding behoort bij het voertuig en deze moet bij het voertuig blijven wanneer deze verkocht wordt ;
- * Monoflex (Monoflex APS / Monoflex AB) kan niet aansprakelijk worden gesteld voor enig gebrek in het produkt zoals veroorzaakt door de schuld of door welk onoordeelkundig gebruik ook van de gebruiker of een persoon voor wie hij aansprakelijk is.

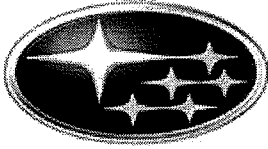

SUBARU

Part number

L105ESC000

(E) N.B.

- * No se olvide de las arandelas normales y de meulle ;
- * Para la masa admisible que pueda remolcar su coche como máximo, consulte a su distribuidor ;
- * Cada 1000 km de uso es necesario comprobar las conexiones del perno (según los pares de apriete dados) ;
- * Estas instrucciones pertenecen al vehículo y deben quedarse en el mismo en el momento de venderlo ;
- * Monoflex (Monoflex APS / MonoflexAB) no asume responsabilidad de ningún tipo por defectos en el producto causados por o debidos a un uso imprudente, tanto por parte del usuario como de cualquier persona bajo su responsabilidad .

(S) OBS:

- * Glöm inte fjäder- och planbrickor ;
- * För den maximalt tillåtna släpvagnsvikten som din bil får dra skall du kontakta din bilhandlare ;
- * Det är nödvändigt att efterdra skruvar och muttrar efter ca. 1000 km ;
- * Denna manual hör till fordonet och måste medfölja fordonet när detta säljs ;
- * Monoflex (Monoflex APS / Monoflex AB) kan inte ställas till svars för några brister hos produkten som förorsakats av felaktigt, försumligt eller omdömeslöst användande av användaren eller annan person som han är ansvarig för .

(I) N.B.

- * Non dimenticare gli anelli di tenuta e le rondelle di bloccaggio ;
- * Per la massa massima consentita trainabile dall'autovettura, consultare il proprio rivenditore ;
- * Occorre stringere i bulloni dopo aver percorso circa 1000 km (basandosi sulle coppie di serraggio indicate) ;
- * Questo manuale appartiene al veicolo e deve restare con il veicolo una volta che questo viene venduto ;
- * Monoflex (Monoflex APS / Monoflex AB) non è in alcun modo responsabile di eventuali mancanze del prodotto causate da negligenza o da cattivo utilizzo da parte dell'utente o di qualsiasi persona di cui l'utente è responsabile.