

# MAZDA

**GB** DOG GUARD  
Installation instruction

**D** HUNDESCHUTZGITTER  
Einbauanleitung

**E** PROTECCIO CONTRA PERRO  
Instrucciones de montaje

**F** GRILLE A CHIEN  
Instructions de montage

**I** PROTEZIONE PER CANE  
Istruzioni di montaggio

**P** PROTECÇÃO PARA CÃES  
Instruções de montagem

**NL** HONDEREK  
Inbouw-instructie

**DK** HUNDEBESKYTTELSE  
Monteringsvejledning

**N** HUNDEBESKYTTELSE  
Monteringsvejledning

**S** HUNDSKYDD  
Monteringsanvisning

**SF** KOIRAVERKKO  
Asennusohje

**CZ** MŘÍŽ PRO PŘEVOZ PSŮ  
Návod k montáži

**H** FÉLMAGAS KUTYARÁCS  
Beszerelési utasítás

**PL** PRZEGRODA ODDZIELAJĄCA DLA PSA  
Instrukcja zabudowy

**GR** ΠΛΕΓΜΑ ΠΡΟΣΤΑΣΙΑΣ ΣΚΥΛΩΝ  
Οδηγίες τοποθέτησης

**RUS** ЗАЩИТНАЯ СЕТКА ДЛЯ СОБАК  
ИНСТРУКЦИЯ ПО УСТАНОВКЕ

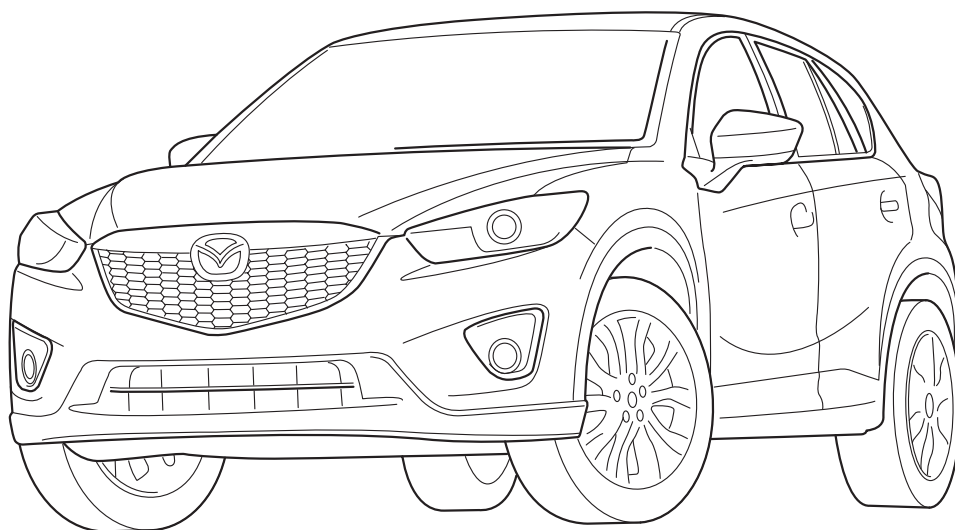

CX-5

KE

Part Number: KD45 - V1 - 280  
KD45 - V1 - 285

Date: 23-11-2011

© Copyright MAZDA

Sheet 1 of 9

Expert Fitment Required  
Montage durch Fachwerkstatt erforderlich  
Montaje sólo por el concesionario  
Montage par spécialiste nécessaire  
E' necessario in officina specializzata  
Especialista em montagem requerido  
Montage door vakman nodig  
Montage ved professionelt værksted påkrævet  
Nødvendig med montering fra fagvejværksted  
Værkstedsmontage erfordras  
Asennus tarpeen merkkikorjaamossa  
Montáž ve specializované dílně nutná  
A szereléshez szakműhely kell  
Konieczny montaż przez warsztat specjalistyczny  
Να τοποθεί απο συνεργείο  
Необходима установка специалистами

Subject to alteration without notice  
 Technische Änderungen vorbehalten  
 Reservadas modificaciones técnicas  
 Sous réserve de modifications techniques  
 Con riserva di apportare modifiche tecniche  
 Reservamo-nos o direito a alterações técnicas  
 Technische wijzigingen voorbehouden  
 Med forbehold for tekniske ændringer

Tekniske forendringer forbeholdes  
 Med reservation för tekniska ändringar  
 Tekniset muutokset pidätetään  
 Technické zmeny vyhrazeny  
 A változtatások technika jogát fenntartjuk  
 Zmiany techniczne zastrzeżone  
 Επιφυλασσόμεθα για αλλαγές  
 Можно изменять без уведомления



- (GB)** Location/Position Arrow
- (D)** Positionspfeil
- (E)** Flecha de posición
- (F)** Flèche de Position
- (I)** Freccia di posizione
- (P)** Flexa de posição
- (NL)** Lokatie/Positie pijl
- (DK)** Lokaliseringspil
- (N)** Posisjonspil
- (S)** Positionpil
- (SF)** Paikannusnuoli
- (CZ)** Šipka na pozici
- (H)** Helyzetjelző nyíl
- (PL)** Strzałka położenia
- (GR)** Βέλος θέσης
- (RUS)** Позиция



- (GB)** Movement Arrow
- (D)** Bewegungspfeil
- (E)** Flecha de movimiento
- (F)** Flèche indiquant sens du vouvement
- (I)** Freccia di movimentov
- (P)** Flexa de movimento
- (NL)** Richtingspijl
- (DK)** Bevægelsespil
- (N)** Bevegelsespil
- (S)** Rörelsepil
- (SF)** Liikesuuntanuoli
- (CZ)** Šipka pohybu
- (H)** Mozgásirányjelző nyíl
- (PL)** Strzałka kierunku ruchu
- (GR)** Βέλος κίνησης
- (RUS)** Стрелка по направлению

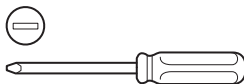

- (GB)** Use Flat End Screwdriver
- (D)** Schraubenzieher verwenden
- (E)** Utilizar destornillador
- (F)** Utiliser tournevis
- (I)** Utilizzare cacciavite
- (P)** Utilizar chave de fendas
- (NL)** Zaaggleuvschroevendraaier
- (DK)** Skruetrækker anvendes
- (N)** Bruk skrujern
- (S)** Använd skruvmejsel för raka spår
- (SF)** Käytä ruuvitalttaa
- (CZ)** Použít šroubovák
- (H)** Használjon csavarhívót
- (PL)** Stosować śrubokręt
- (GR)** Χρησιμοποιείτε κατασβίδ
- (RUS)** Используйте крестовую отвёртку

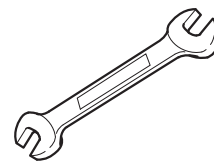

- (GB)** Tighten
- (D)** Festdrehen
- (E)** Apretar fuerte girando
- (F)** Bien serrer
- (I)** Stringere bene
- (P)** Apertar bem
- (NL)** Vastdraaien
- (DK)** Tilspændes
- (N)** Drei fast
- (S)** Dra fast
- (SF)** Kiristä tiukalle
- (CZ)** Utáhnout
- (H)** Feszesen csavarja be
- (PL)** Silnie dokręcić
- (GR)** Περιοτροφή γερά
- (RUS)** Закрутите

**KD45-V1-280**

**A**

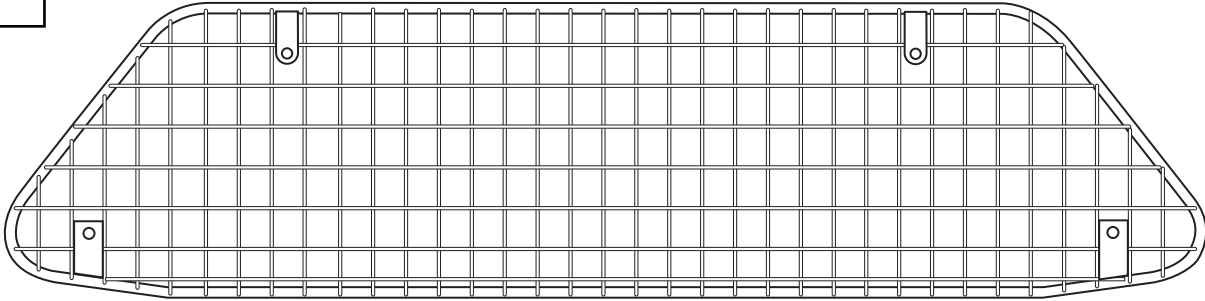

1x

**B**

**RH**

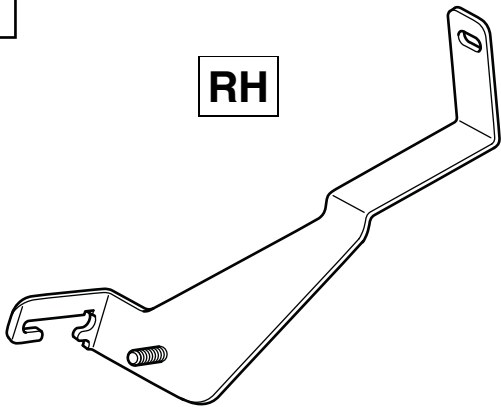

1x

**C**

**LH**

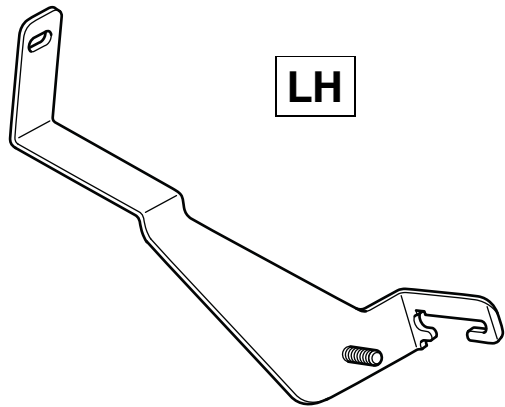

1x

**D**



2x

**E**

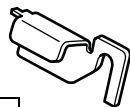

**RH**

1x

**F**

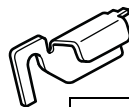

**LH**

1x

**G**



2x

**H**

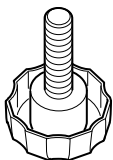

6x

**I**



2x

**J**



4x

**KD45-V1-285**

**B**

**RH**

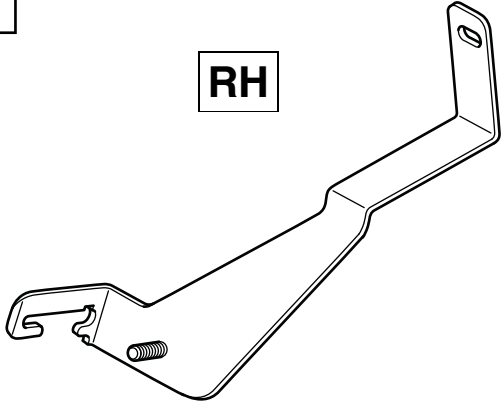

1x

**C**

**LH**

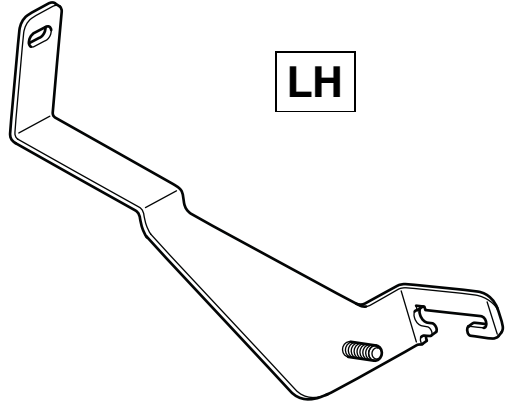

1x

**D**



2x

**E**

**RH**

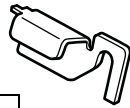

1x

**F**

**LH**

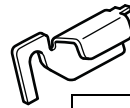

1x

**G**



2x

**H**

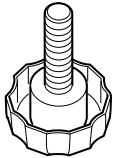

6x

**I**



2x

**J**



4x

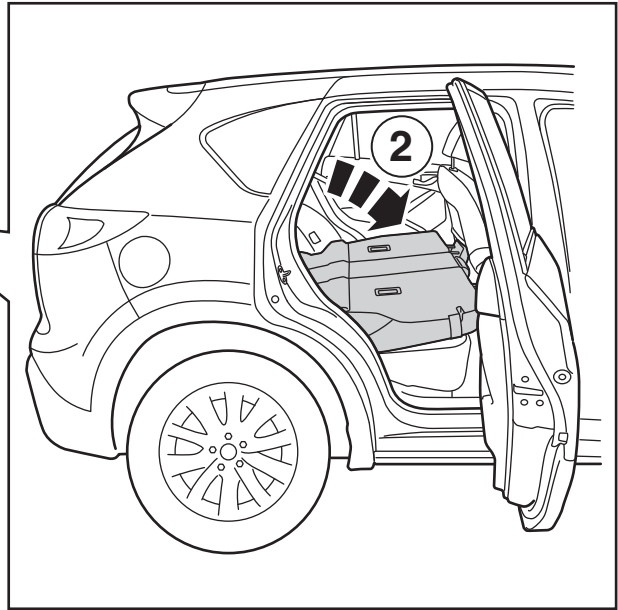
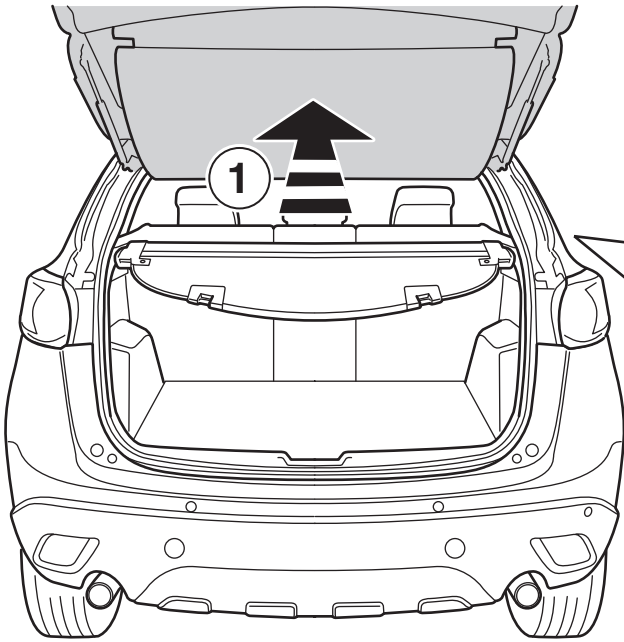

**1**

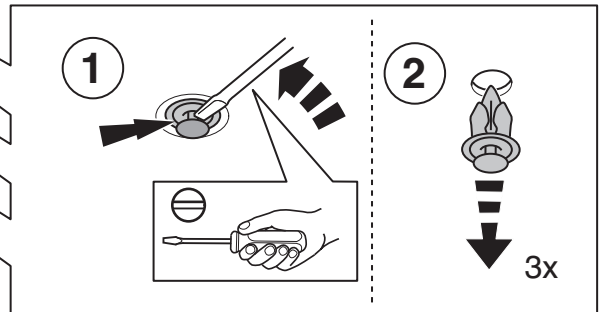
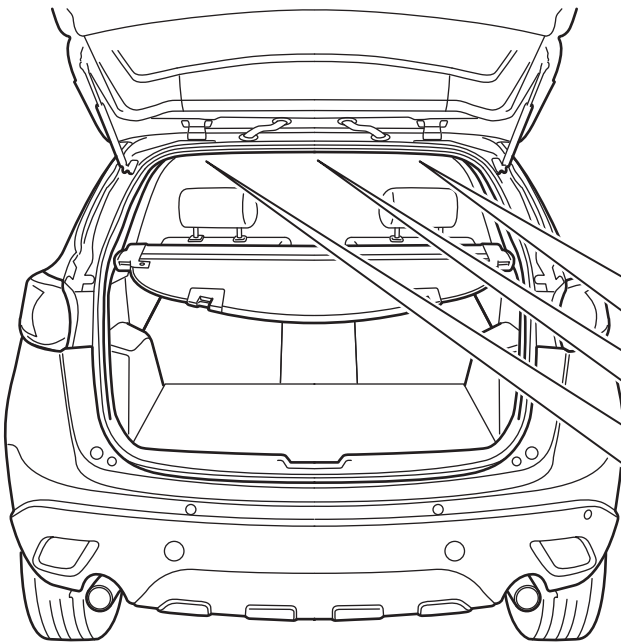

**2**

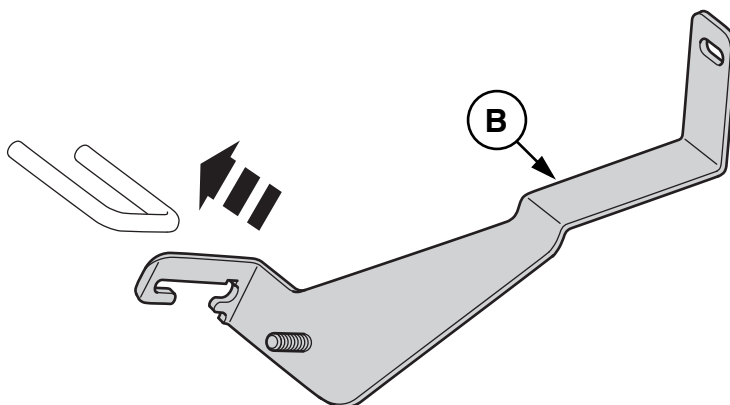
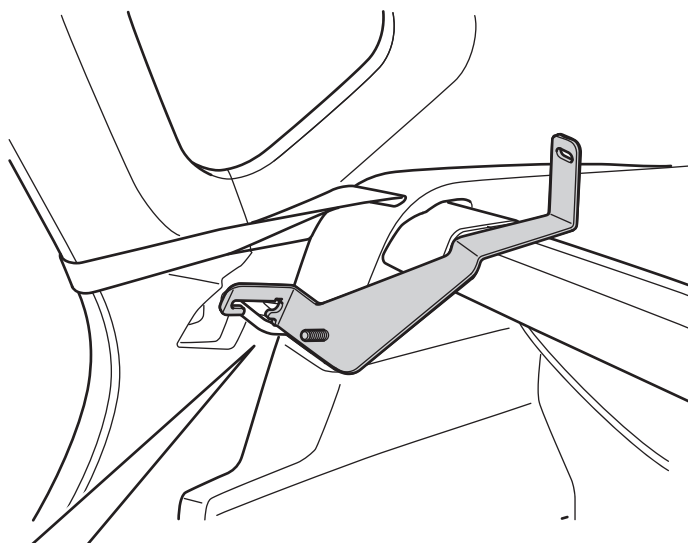
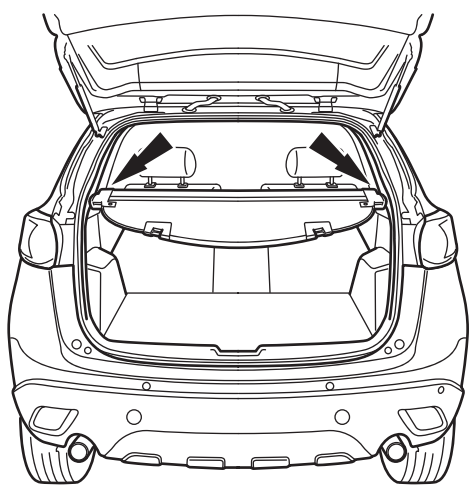
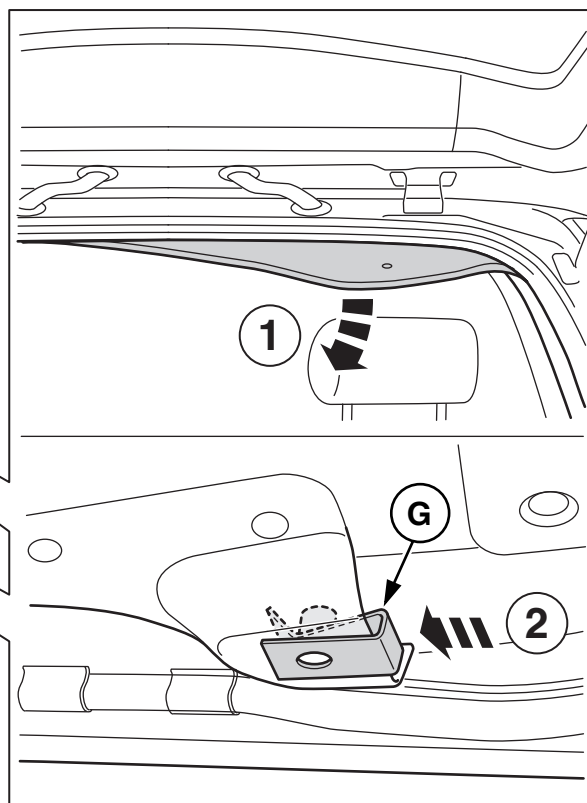
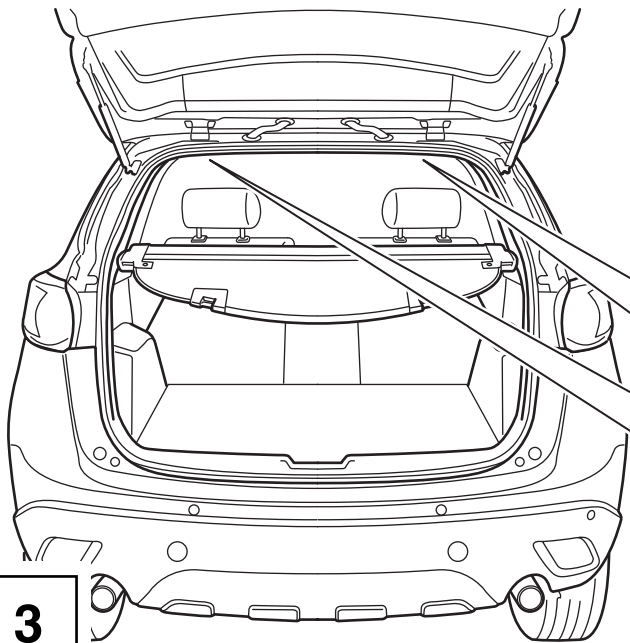

4



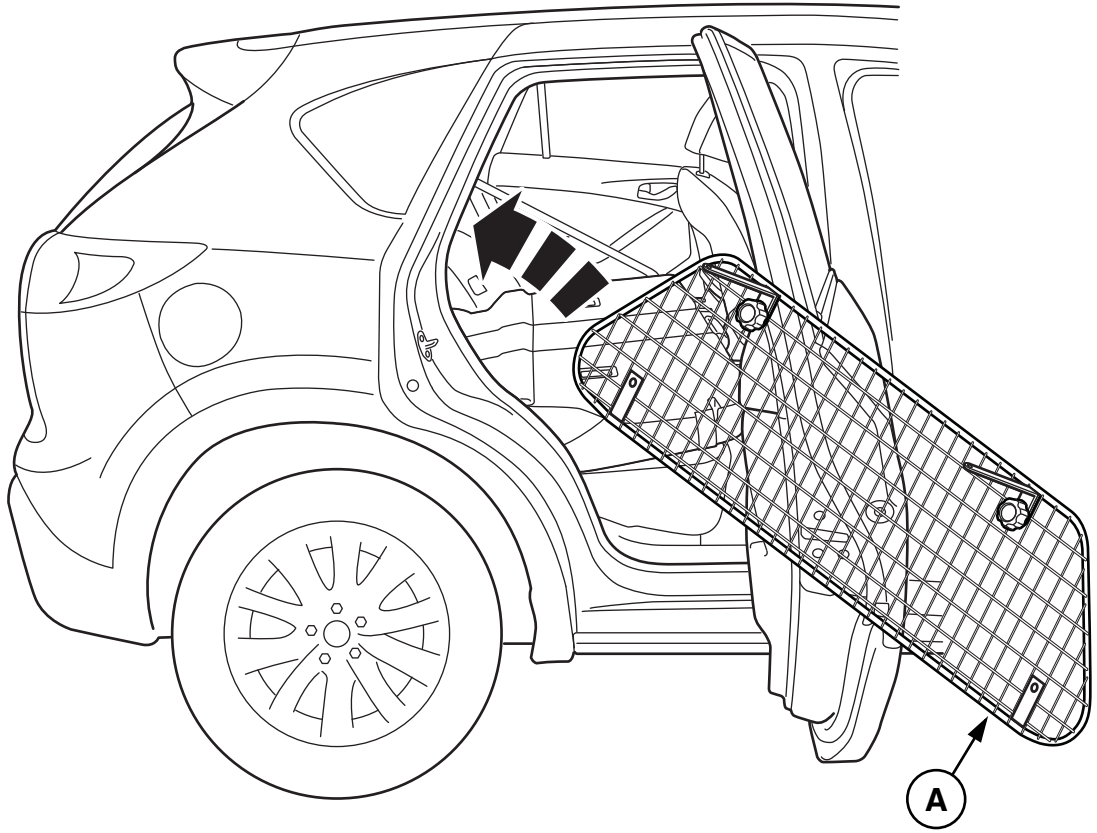

**7**

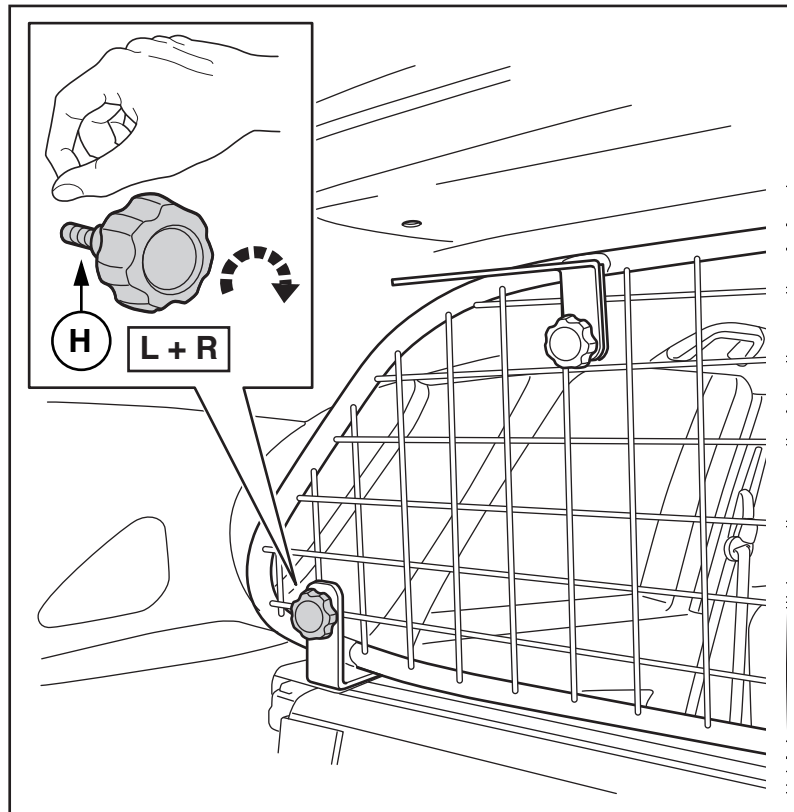
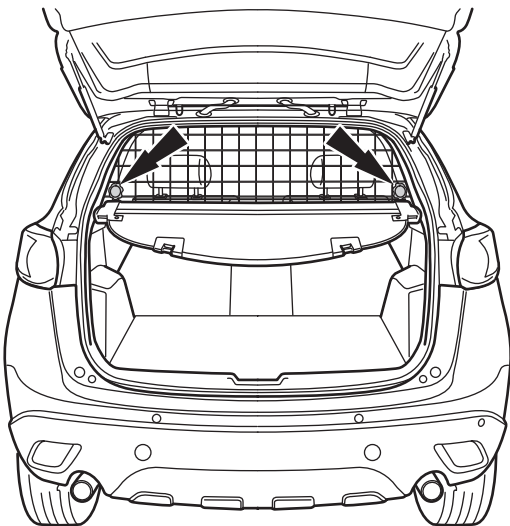

**8**



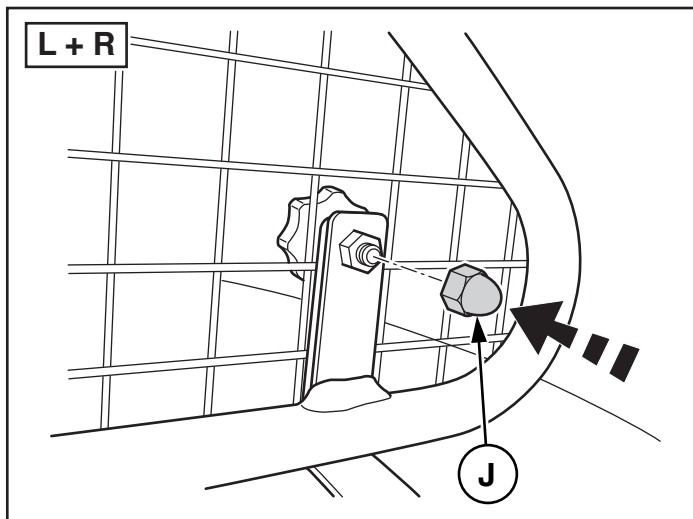
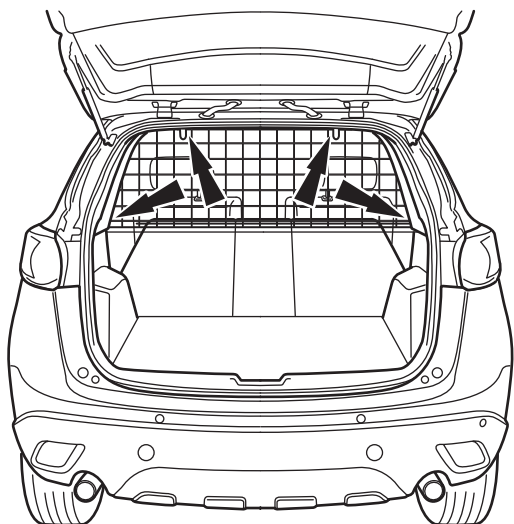

9

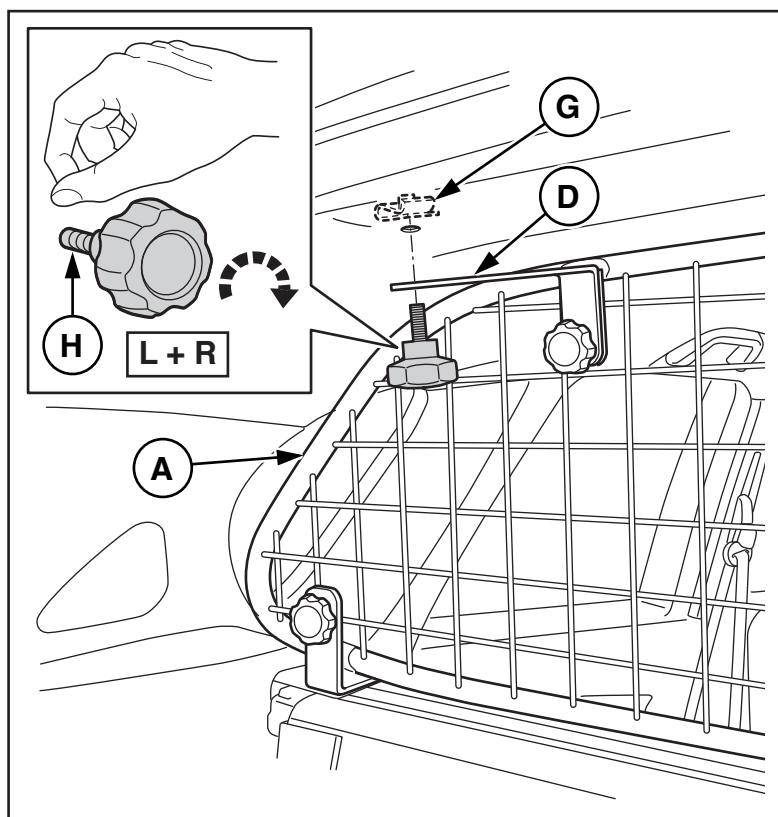
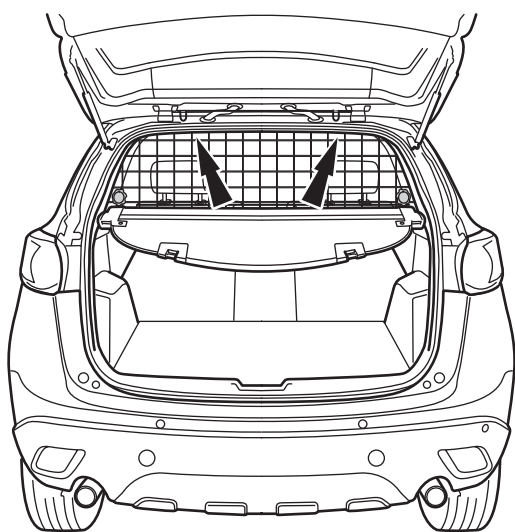

10