

# MAZDA

<b>GB</b>	<b>ROOF RACK</b> Installation Instruction
<b>D</b>	<b>DACHGEPÄCKTRÄGER</b> Einbauanleitung
<b>E</b>	<b>PORTAEQUIPAJES</b> Instrucciones de montaje
<b>F</b>	<b>BARRES DE TOIT</b> Instructions de montage
<b>I</b>	<b>PORTA-BAGAGLI SUL TETTO</b> Istruzioni di montaggio
<b>P</b>	<b>PORTA-BAGAGENS DE TEJADILHO</b> Instruções de montagem
<b>NL</b>	<b>DAK DRAGER</b> Inbouw-instructie
<b>DK</b>	<b>TAGBAGAGEBÆRER</b> Monteringsvejledning

<b>N</b>	<b>TAKGRIND</b> Monteringsveiledning
<b>S</b>	<b>LASTHÅLLARE</b> Monteringsanvisning
<b>SF</b>	<b>TAAKKATELINEEN</b> Asennusohje
<b>CZ</b>	<b>LYŽINY</b> Návod k montáži
<b>H</b>	<b>TETŐCSOMAGTARTÓ</b> Beszerelési utasítás
<b>PL</b>	<b>BAGAŻNIK DACHOWY</b> Instrukcja zabudowy
<b>GR</b>	<b>Σχάρα οροφής</b> Οδηγίες τοποθέτησης
<b>RUS</b>	<b>БАГАЖНИК НА КРЫШУ</b> инструкция по установке

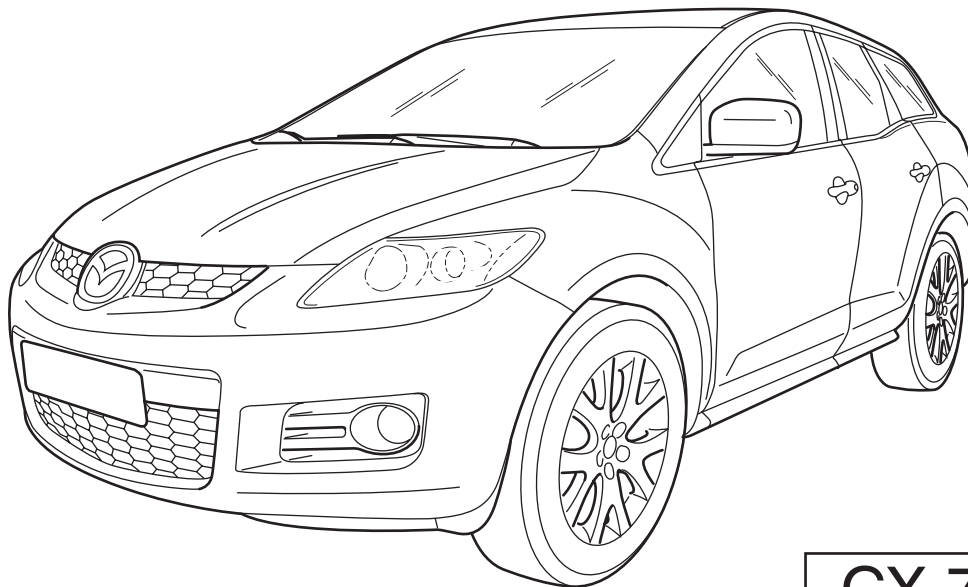

**CX-7** | **ER**

Part Number: EH15-V4-701

Date: 07-10-2008

© Copyright MAZDA

Sheet 1 of 9

Expert Fitment Required  
Montage durch Fachwerkstatt erforderlich  
Montaje sólo por el concesionario  
Montage par spécialiste nécessaire  
E' necessario in officina specializzata  
Especialista em montagem requerido  
Montage door vakman nodig  
Montage ved professionelt værksted påkrævet  
Nødvendig med montering fra fagvejværksted  
Verkstadsmontage erfordras  
Asennus tarpeen merkkikorjaamossa  
Montáž ve specializované dílně nutná  
A szereléshez szakműhely kell  
Konieczny montaż przez warsztat specjalistyczny  
Να τοποθεί απο συνεργείο  
Необходима установка специалистами

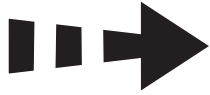

- (GB)** Movement Arrow
- (D)** Bewegungspfeil
- (E)** Flecha de movimiento
- (F)** Flèche indiquant sens du mouvement
- (I)** Freccia di movimento
- (P)** Flexa de movimento
- (NL)** Richtingspijl
- (DK)** Bevægelsespil
- (N)** Bevegelsespil
- (S)** Rörelsepil
- (SF)** Liikesuuntanuoli
- (CZ)** Šipka pohybu
- (H)** Mozgásirányjelző nyíl
- (PL)** Strzałka kierunku ruchu
- (GR)** Βέλος κίνησης
- (RUS)** Стрелка по направлению

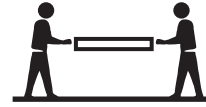

- (GB)** 2 Man Operation Required
- (D)** Nur zu zweit ausführen
- (E)** Realizar sólo entre dos personas
- (F)** Toujours s'y mettre de deux
- (I)** Da eseguire soltanto in due
- (P)** Executar somente a dois
- (NL)** Met 2 personen uitvoeren
- (DK)** Skal udføres af to personer
- (N)** Må utføres av to personer
- (S)** Utförs endast av två personer
- (SF)** Tehtävä kahdestaan
- (CZ)** Provádět jen ve dvou
- (H)** Csak két személy végezheti el
- (PL)** Wykonywać tylko w dwie osoby
- (GR)** Να εκτελεσθεί από δύο άτομα
- (RUS)** Выполняйте вдвоём

**A**

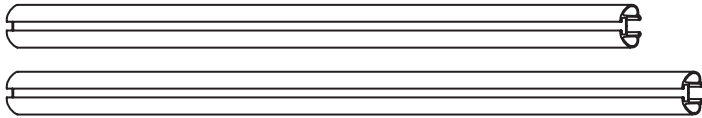

1x

**B**

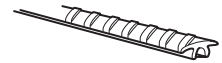

2x

**C**

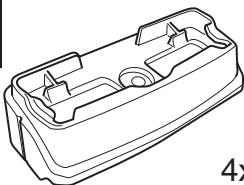

4x

**D**

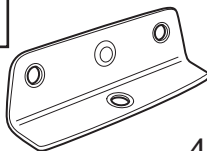

4x

**E**



8x

**F**



4x

**G**



8x

**H**



4x

**I**

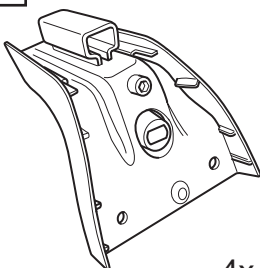

4x

**J**

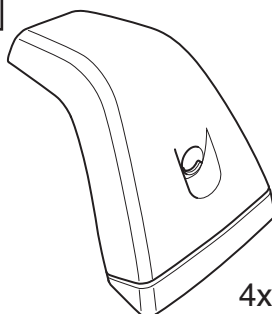

4x

**K**

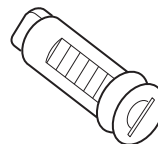

4x

**L**



1x

**M**

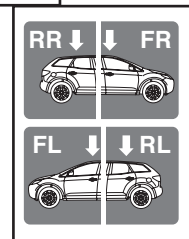

1x

**N**

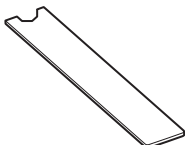

2x

**O**



1x

**P**



4x

**Q**



2x

**R**



2x

1

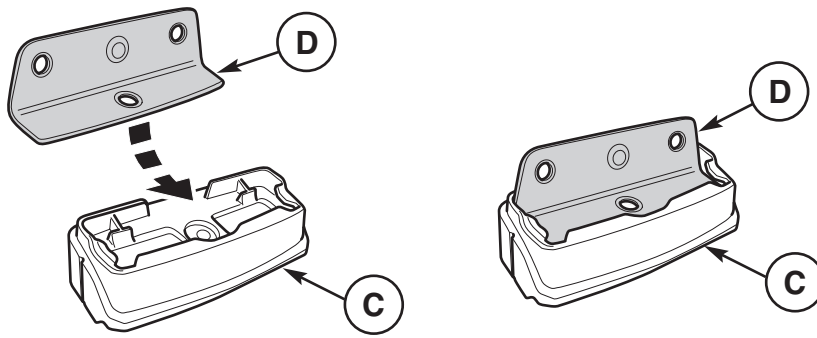

4x

2

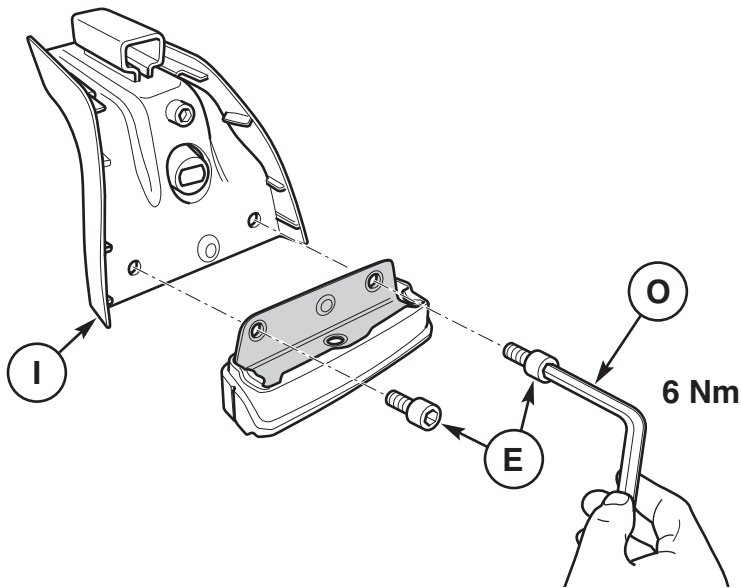

4x

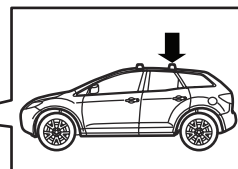
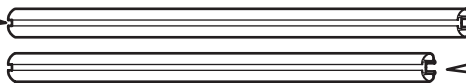
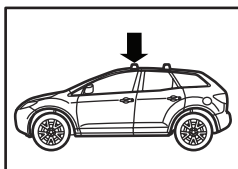
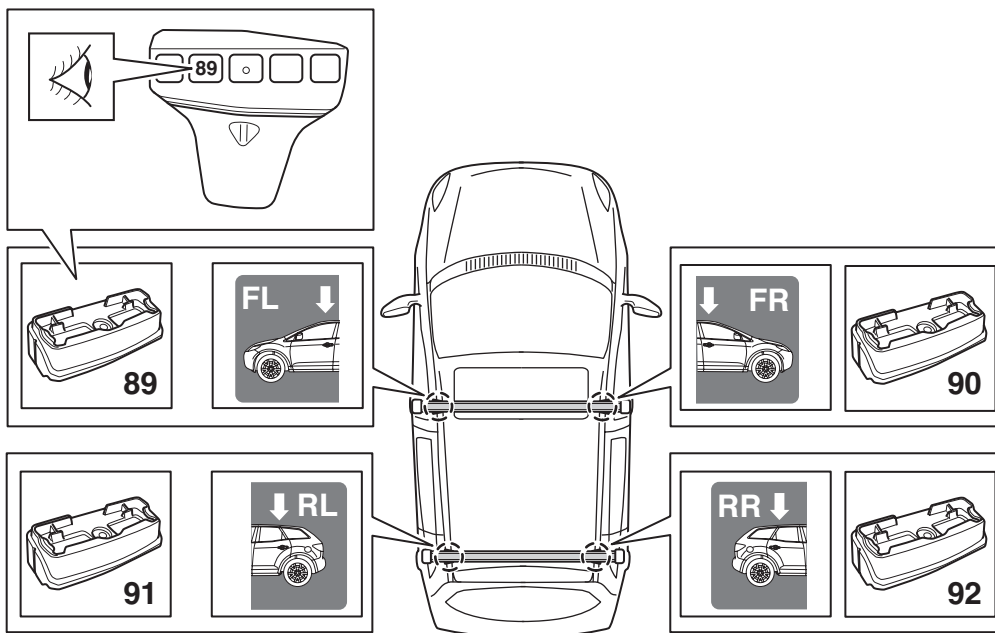

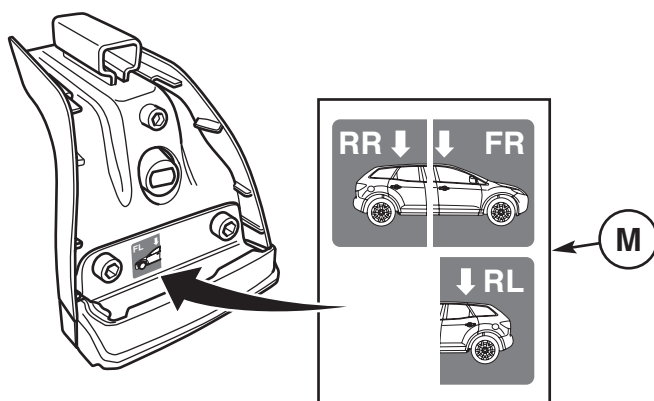

3

4x

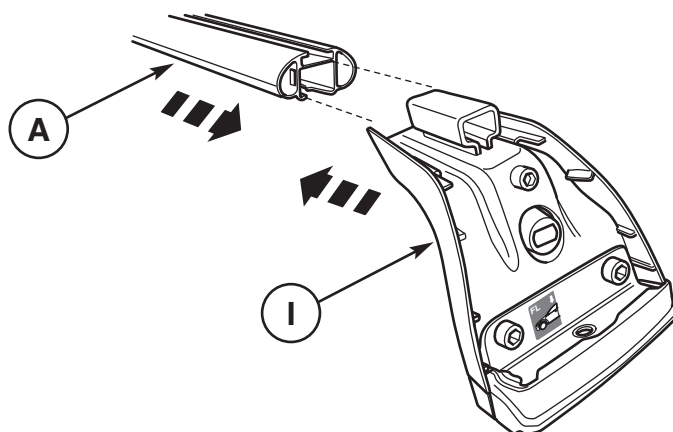

4

4x

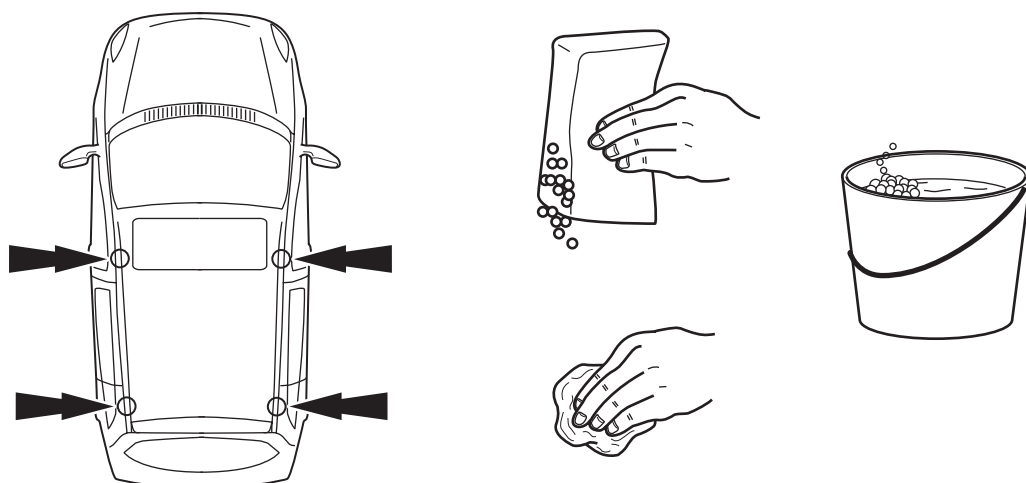

5

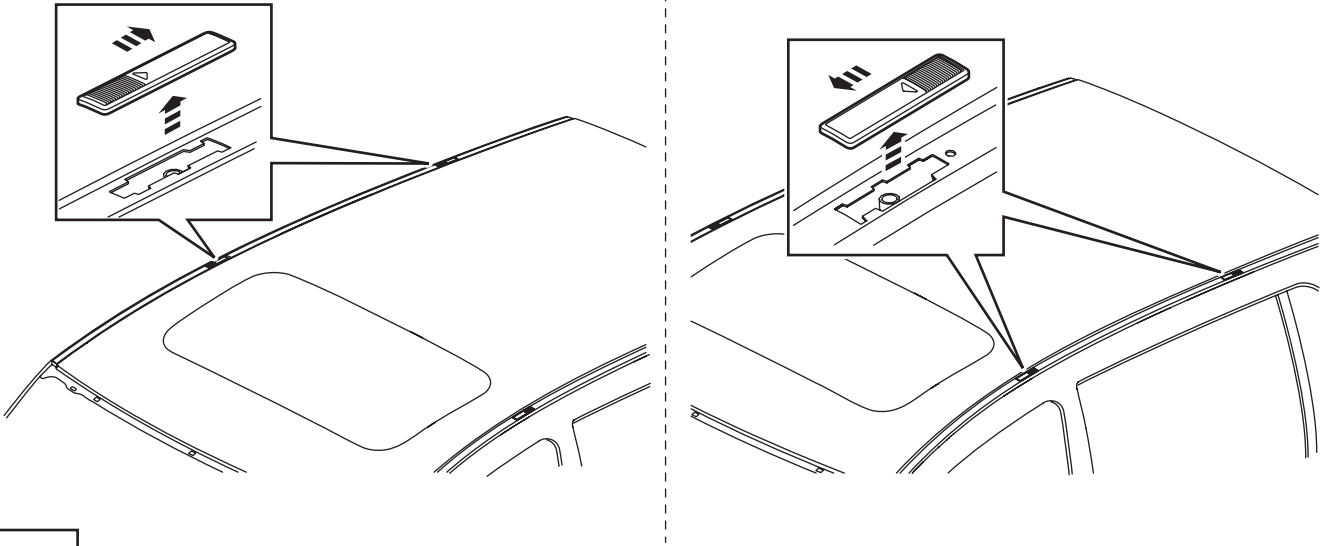

6

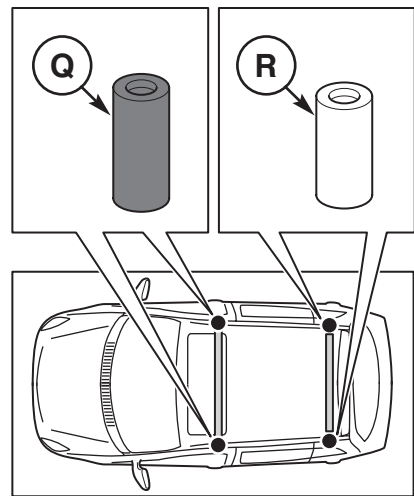
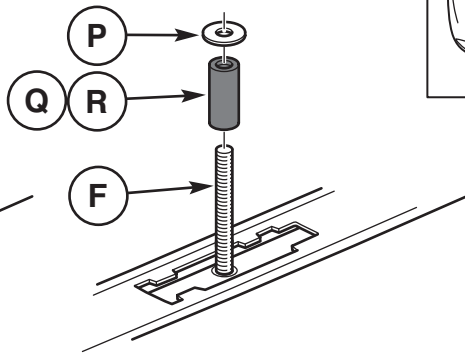
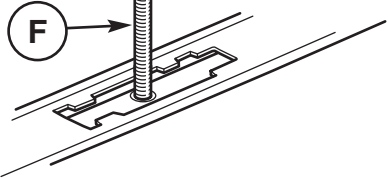
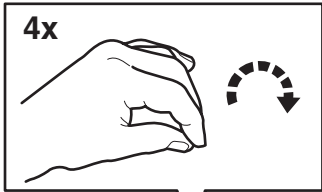

7

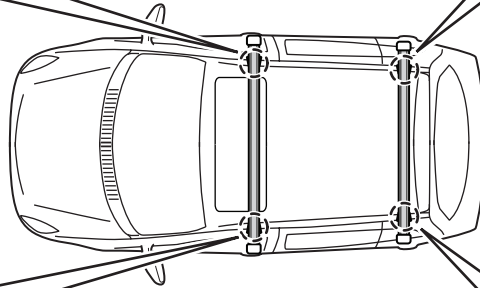
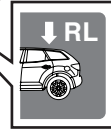
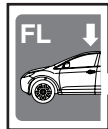
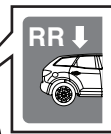
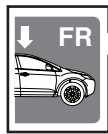
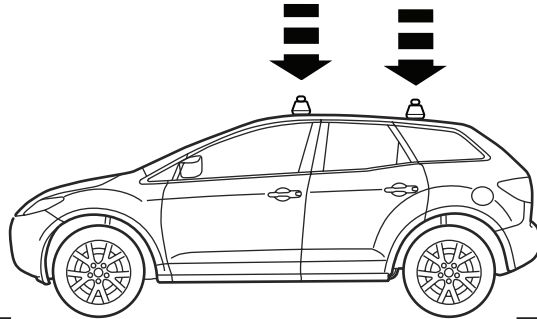
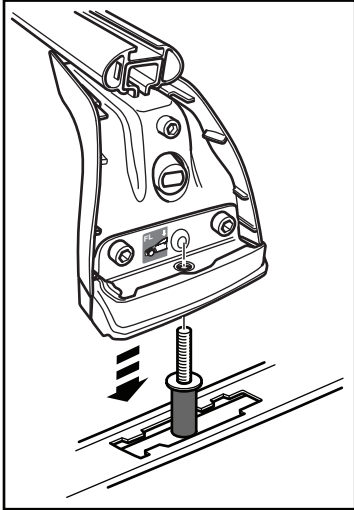
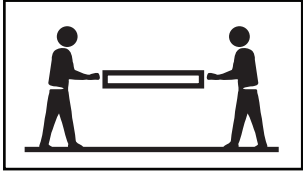

8

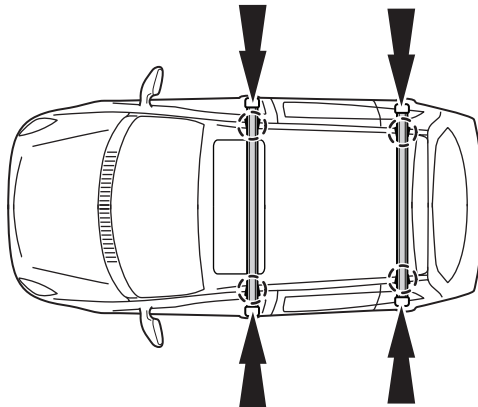
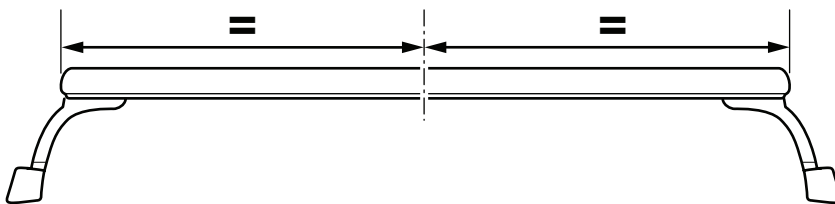

9

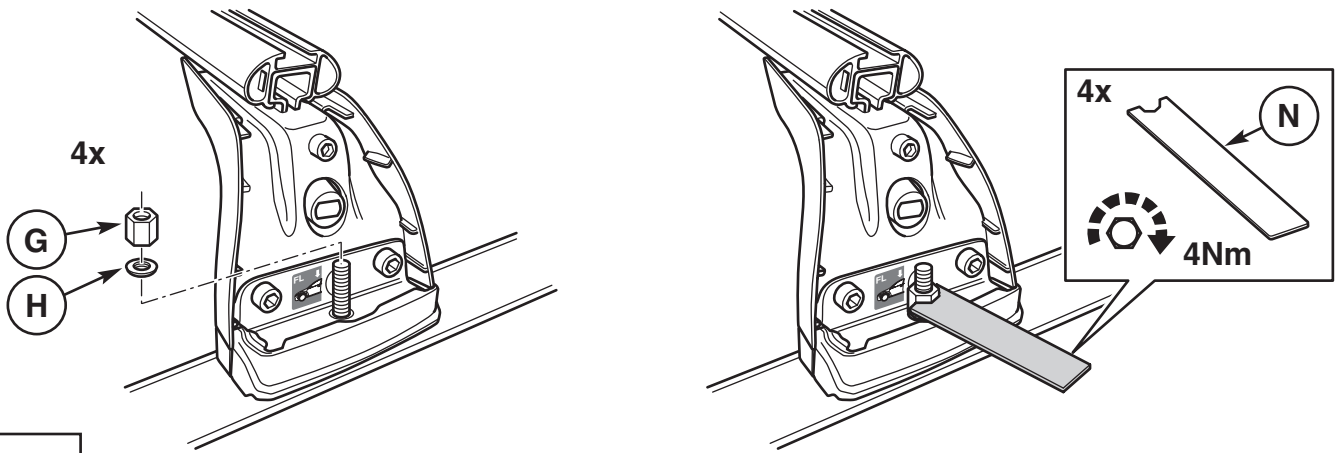

**10**

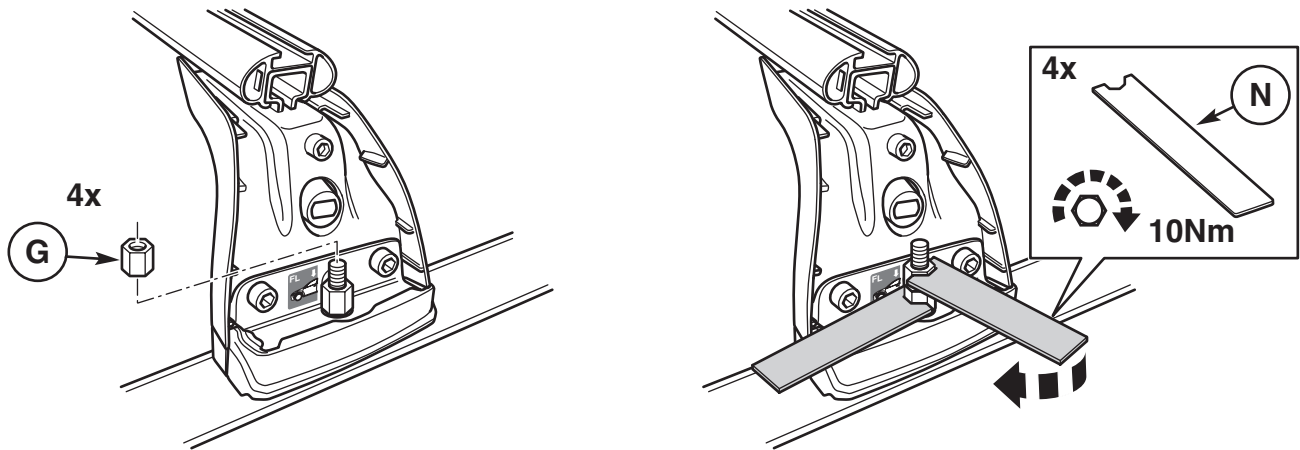

**11**

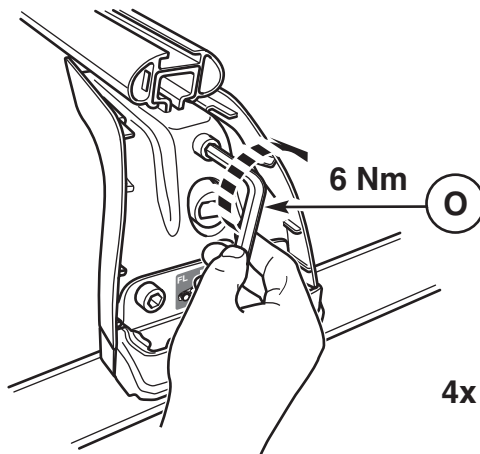



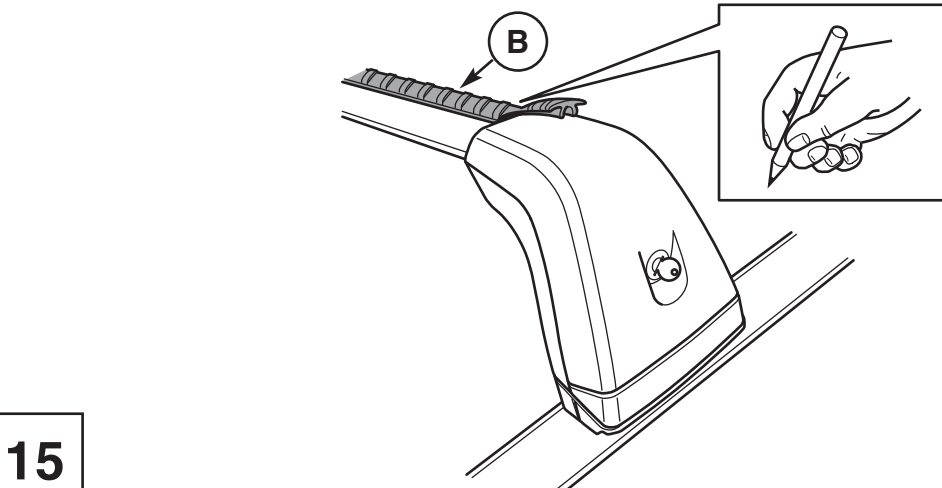
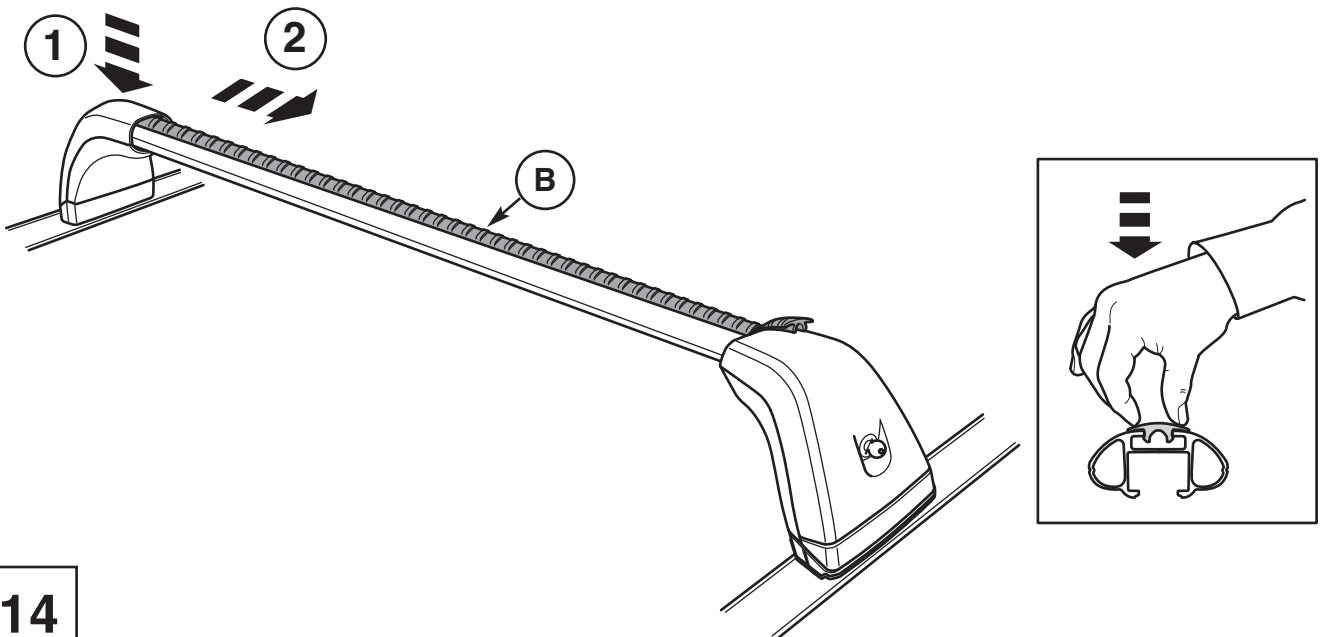
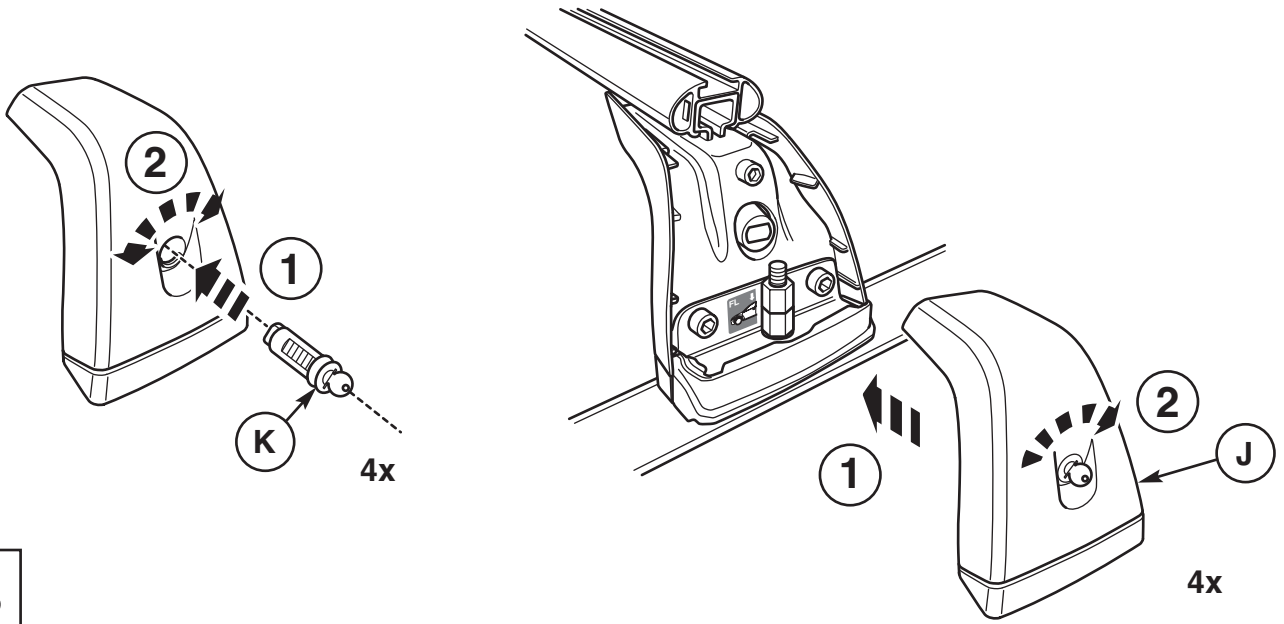

**12**

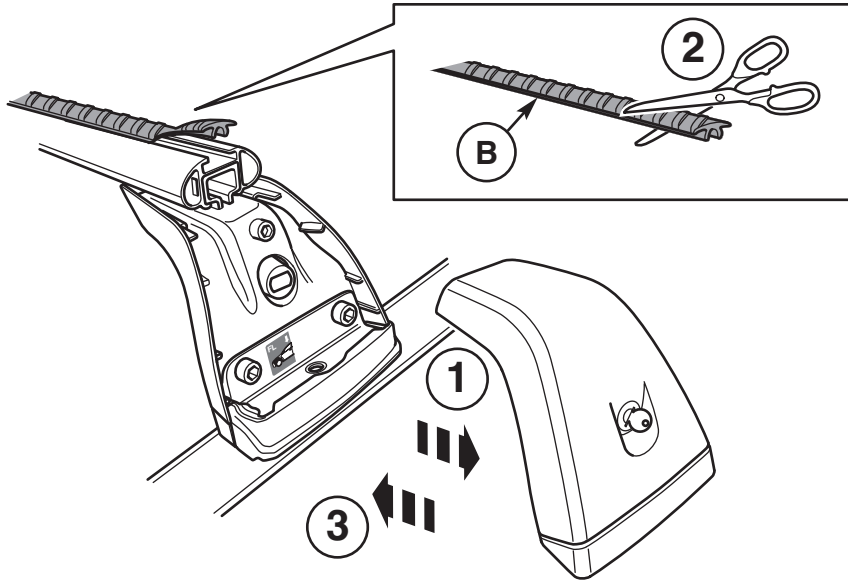





16

		5000 Km 4000 Km 3000 Km 2000 Km 1000 Km
	10 / 11 / 12	
4 Nm 10 Nm 6 Nm		

	
Max. 75 kg	+ 

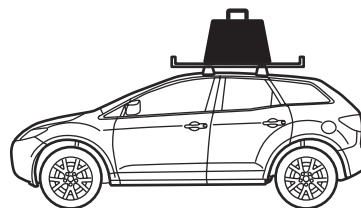

17