



(GB) INSTALLATION INSTRUCTIONS
(DE) MONTAGEANLEITUNG
(FR) MANUEL D'INSTALLATION
(IT) MANUALE DI INSTALLAZIONE

Description/ Application	Fixed towbar '10MY~ Outback
Beschreibung/ Verwendung	Anhängerkupplung '10MY~ Outback
Désignation/ Application	Crochet d'attelage '10MY~ Outback
Descrizione/ Applicazione	Gancio di traino '10MY~ Outback
Part Number/ Teilenummer/ Référence produit/ Codice Pezzo	L105EAJ620



Contents
Inhalt
Contenu
Contenuto

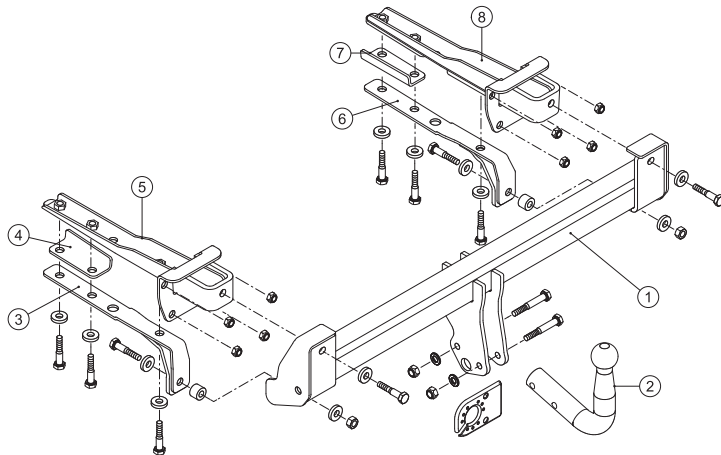
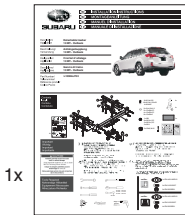

- 8x M12x1,25x60
- 2x M12x1,25x70
- 2x M12x1,75x80
- 1x [Washer]
- 2x 13x25x2,5
- 12x 13x30x6
- 1x [Bracket]
- 8x M10x1,25
- 2x M12x1,25
- 2x M12x1,75
- 2x 25x6,3x18
- 1x [Warning Icon]

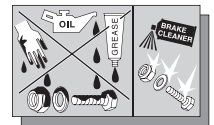

Important
Wichtig
Important
Importante

CAUTION
 Indicates potential hazard that could result in vehicle damage.
 Zeigt potentielle Gefahren an, die zu Schäden am Fahrzeug führen können.
 Indique les dangers potentiels pouvant endommager le véhicule.
 Indica potenziale pericolo che può comportare danni all'autovettura.

(GB) Please read this manual and follow the instructions carefully. To emphasize important information, the symbol and words: **CAUTION** and **NOTE** have been used. Pay particular attention to the message highlighted by these signal words.
NOTE: Indicates special information to make maintenance easier or instructions clearer.

(DE) Bitte diese Montageanleitung lesen und die Anweisungen sorgfältig beachten. Zum Hervorheben wichtiger Informationen werden die Symbole und Begriffe **ACHTUNG** und **HINWEIS** benutzt. Achten sie besonders auf den durch die folgenden Begriffe hervorgehobenen Hinweis.
HINWEIS: Markiert spezielle Informationen, um die Wartung zu erleichtern oder Anweisungen zu verdeutlichen.

(FR) Veuillez lire attentivement et respecter ce mode d'emploi et ses instructions. Les symboles et les mots **ATTENTION** et **REMARQUE** sont particulièrement importants et mettent en évidence les informations qui requièrent votre attention.
REMARQUE: Donne des informations spécifiques pour faciliter la maintenance ou clarifier les instructions.

(IT) Si prega di leggere il presente manuale e di seguire le istruzioni in esso contenute. Il simbolo e le parole **ATTENZIONE** e **INFORMAZIONE** sono particolarmente importanti e mettono in evidenza informazioni accentuate da tali simboli/parole.
INFORMAZIONE: Indica speciali informazioni per facilitare la manutenzione o per illustrare le istruzioni.

Tools Required
Notwendige Hilfsmittel
Équipement Nécessaire
Attrezzatura Richiesta

				1x PN 44011AE010
				2x PN 010510307
				2x PN 902350001
				2x PN 44011AE010
				4x PN 010510307
				4x PN 902350001



SUBARU

Model name	Outback
Model year	'10MY →
Body type	—
Model series	BRF, BRD, BR9
Car homologation nr.	e1*2007/46*0079*
Max. car weight	2100kg
Max. towing weight	2000 kg
Max. vertical weight	80 kg
D-value	10,05 kN
Type nr.	SBL50Q-2
Towbar EEC approval nr.:	13*94/20*94/20*3092*00
Installation time	1,5 hrs

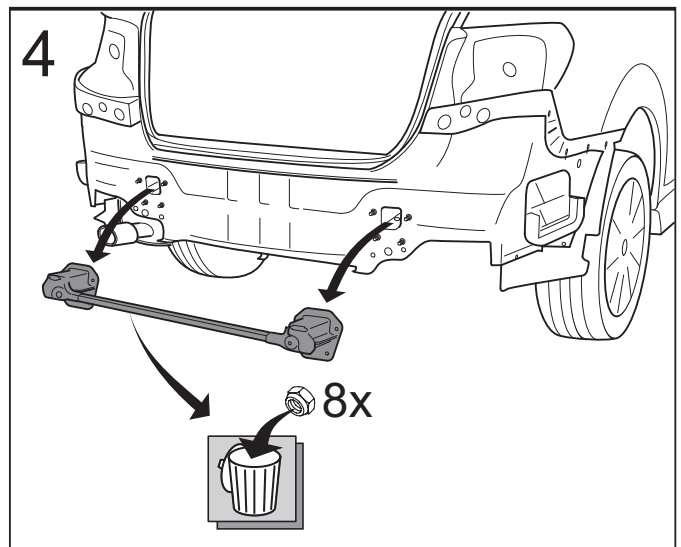
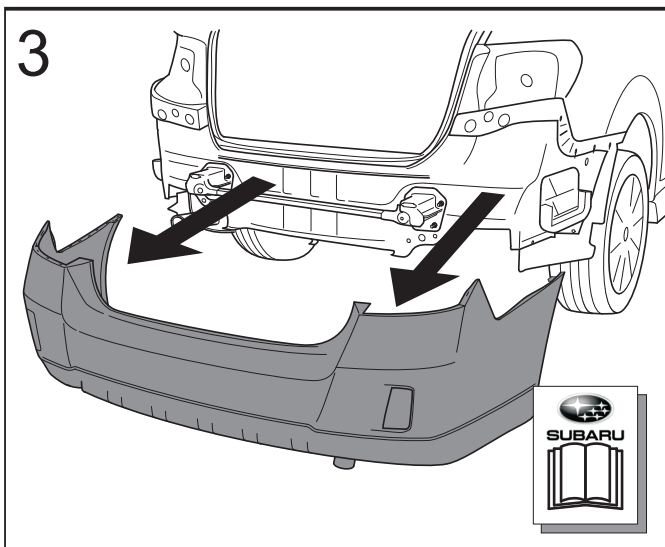
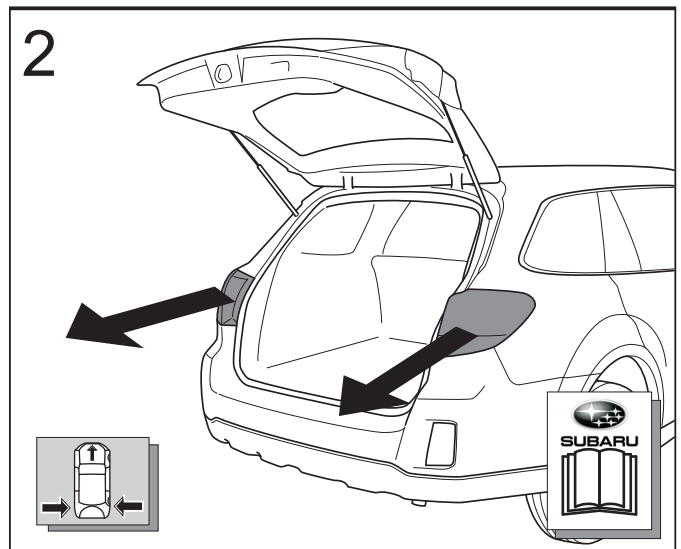
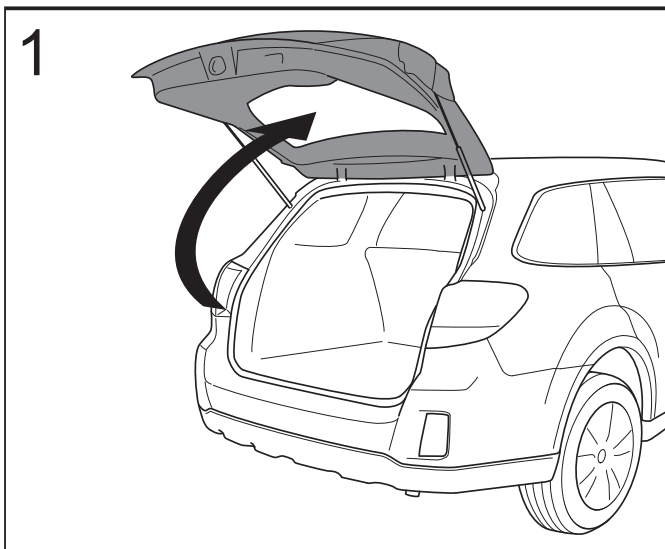



SUBARU

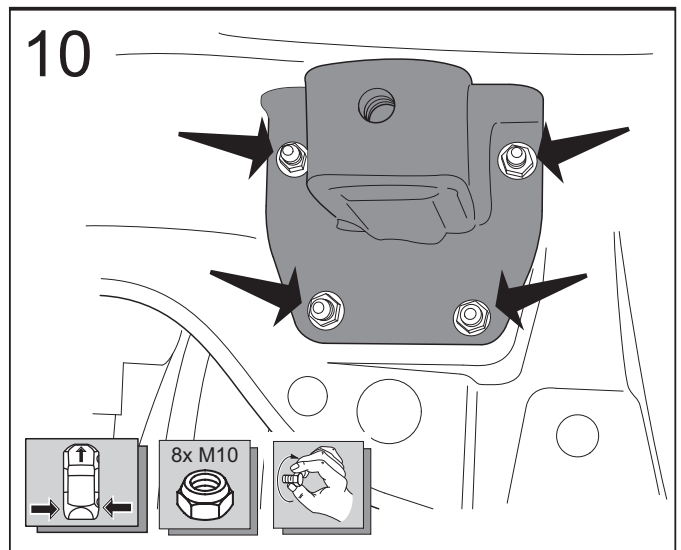
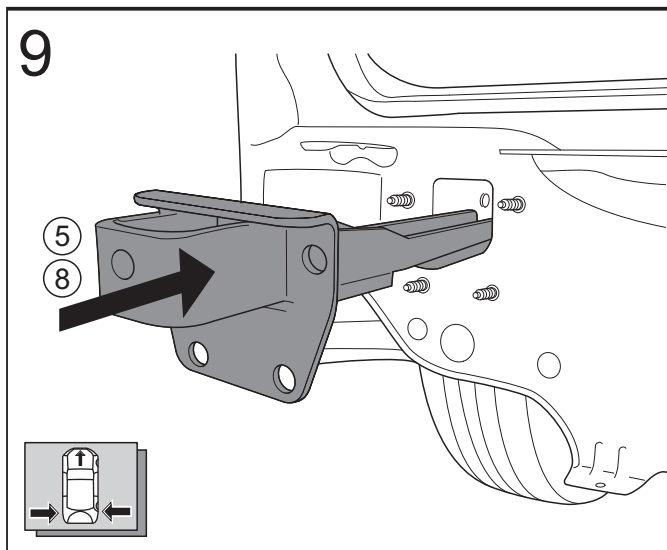
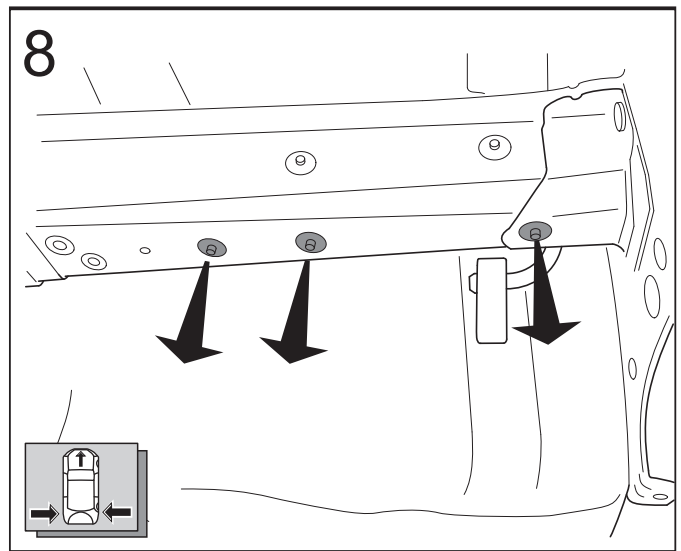
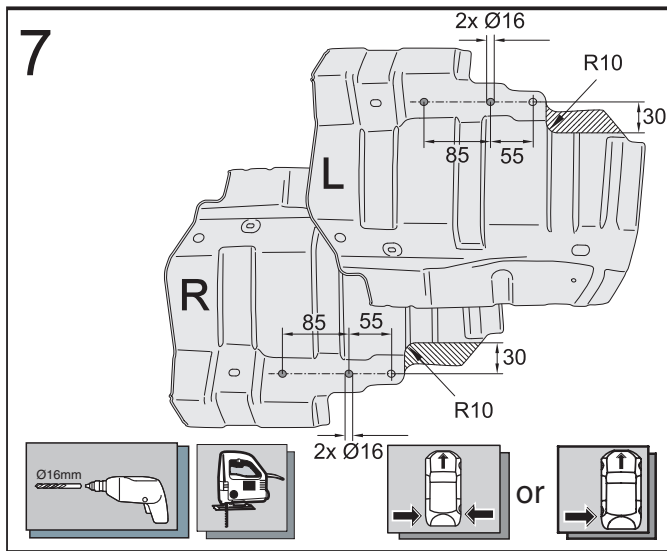
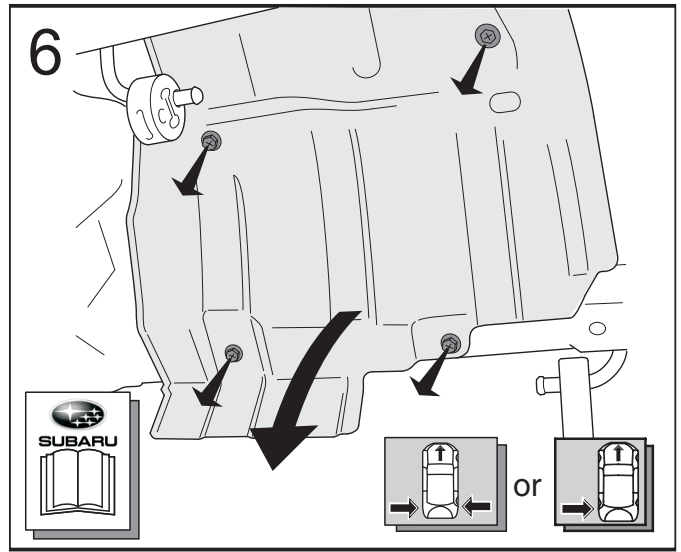
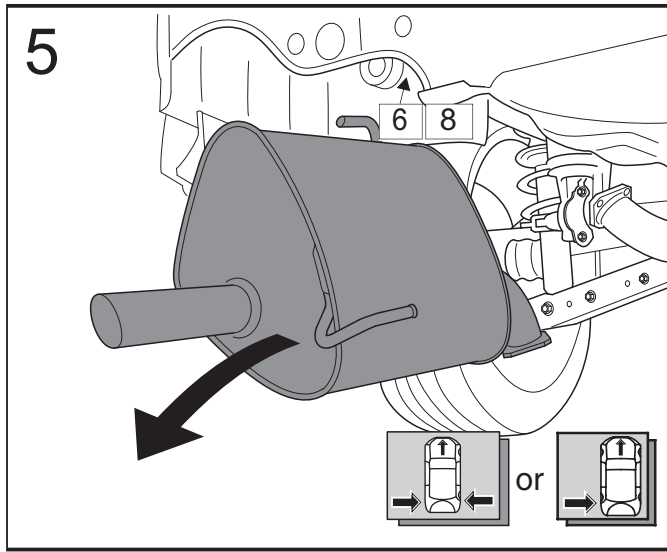



SUBARU

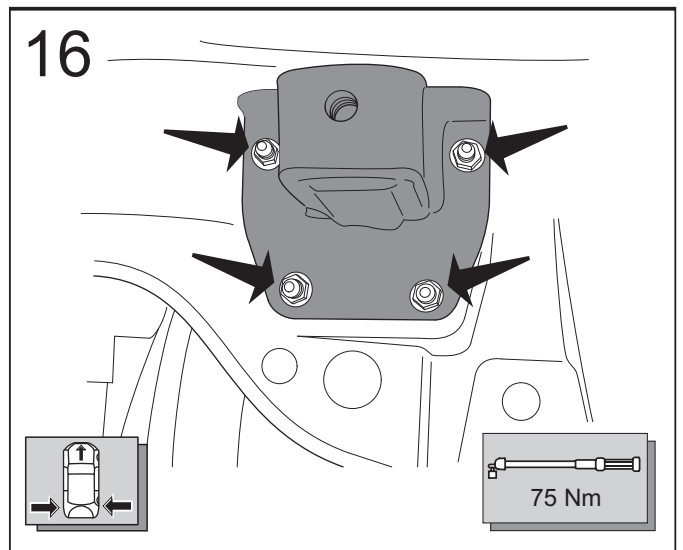
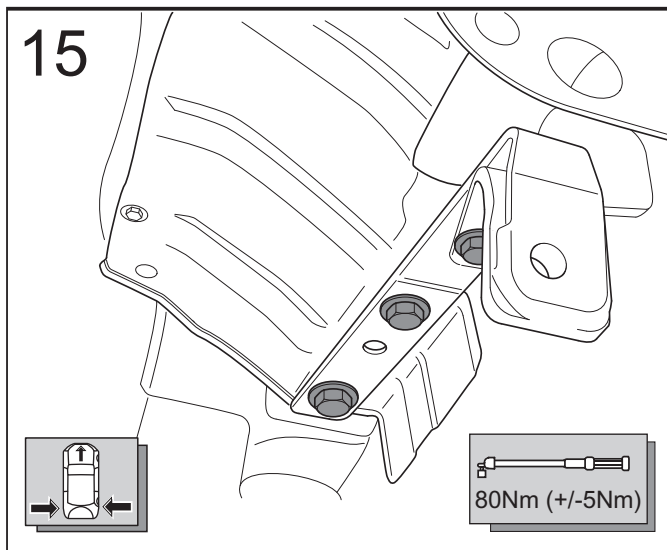
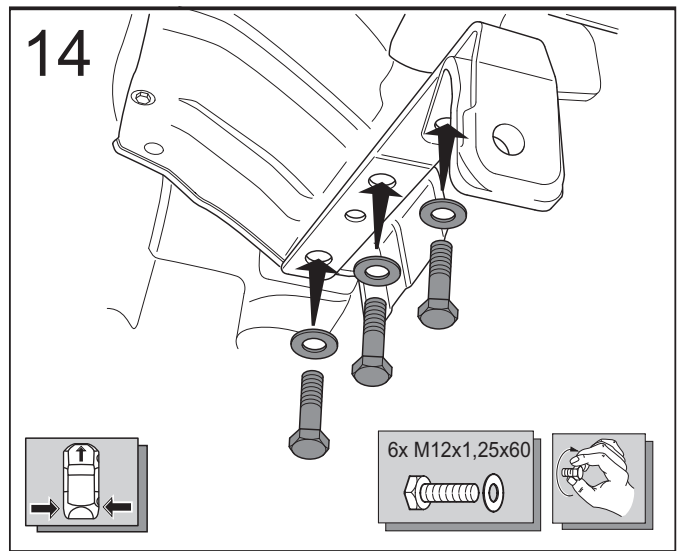
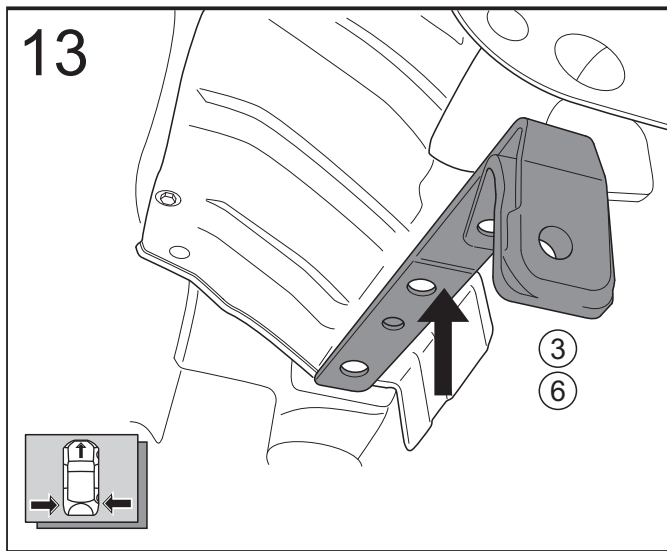
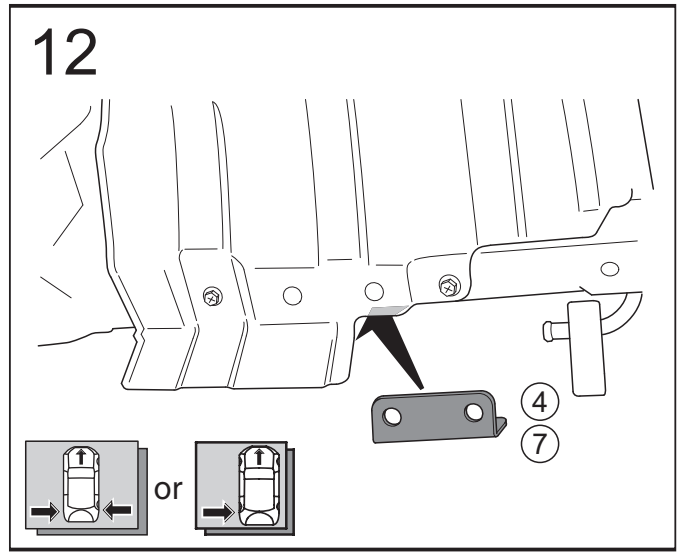
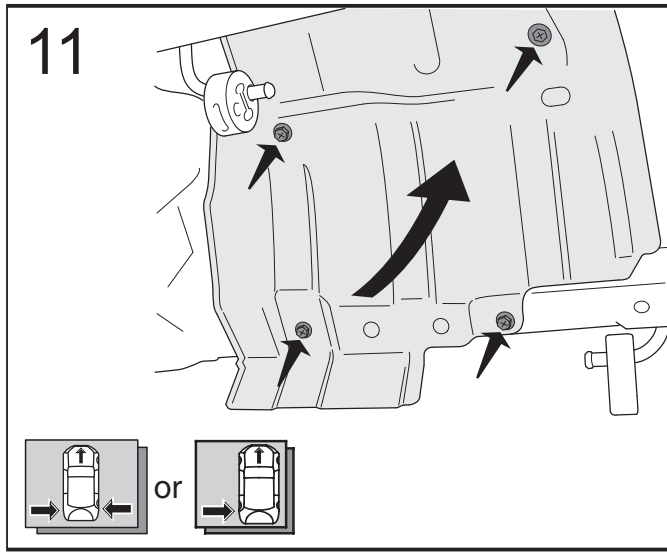



SUBARU

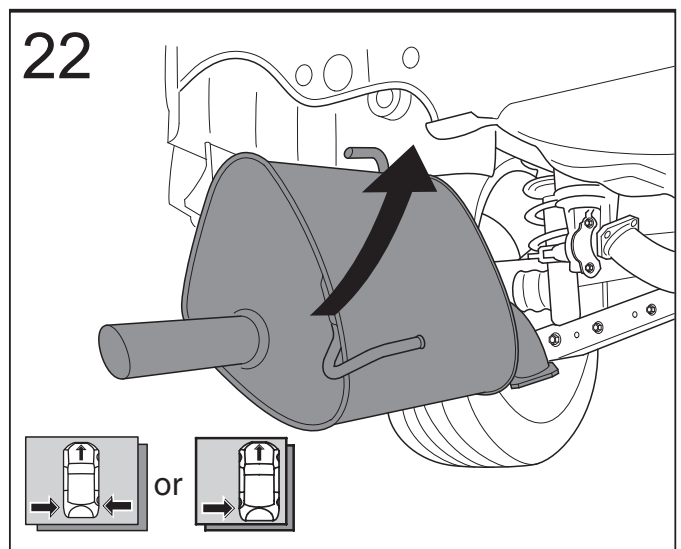
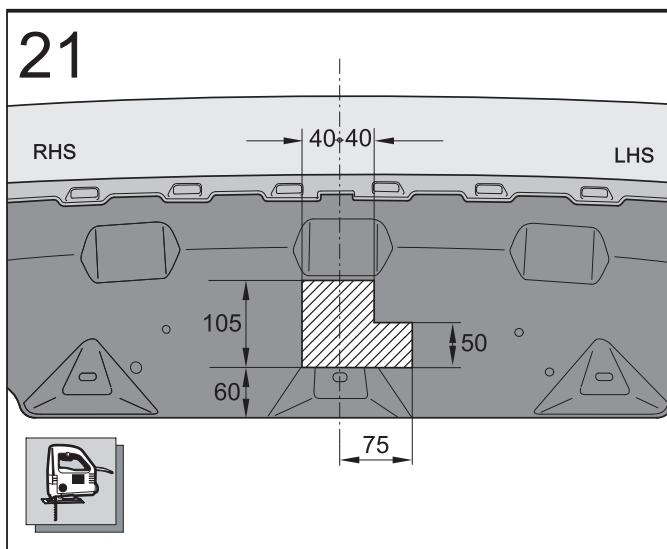
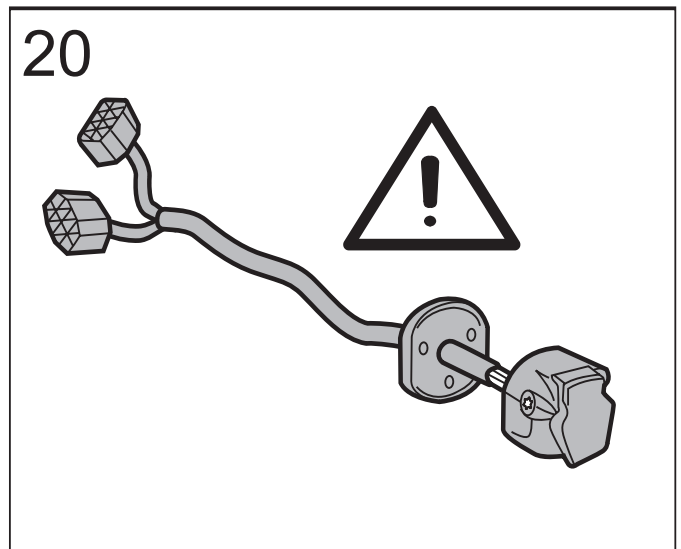
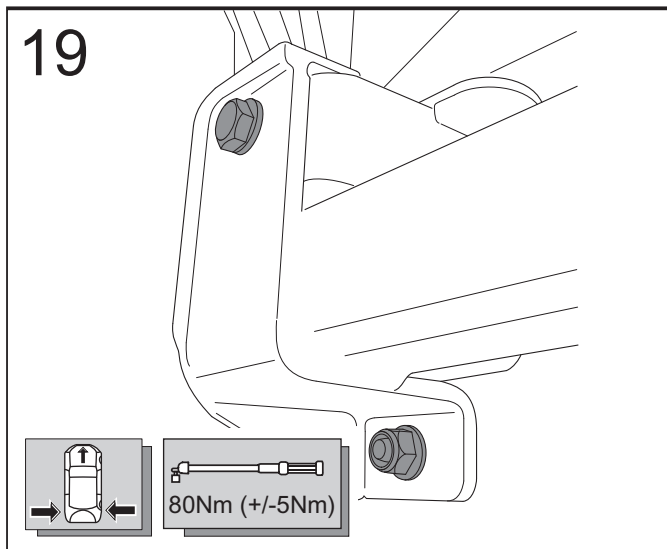
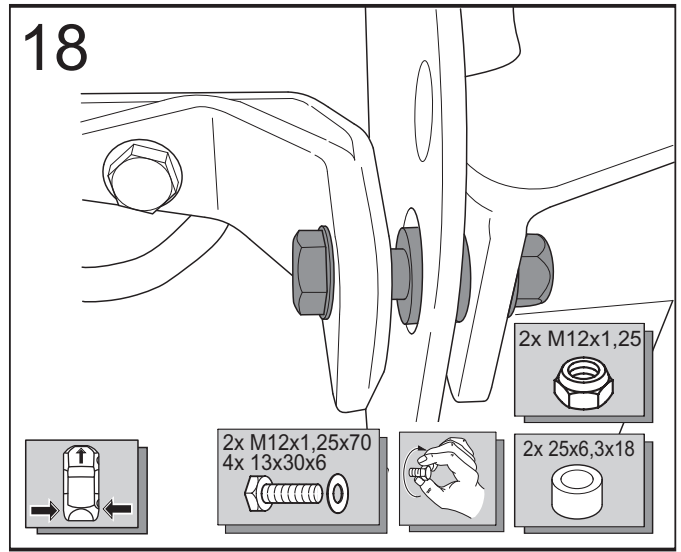
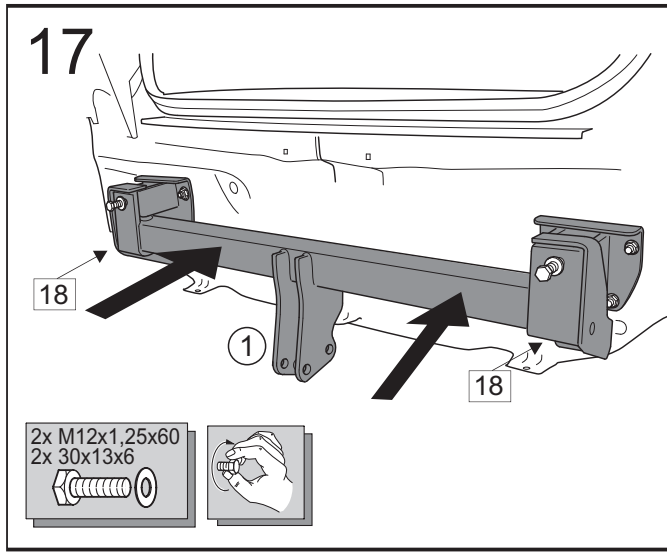



SUBARU

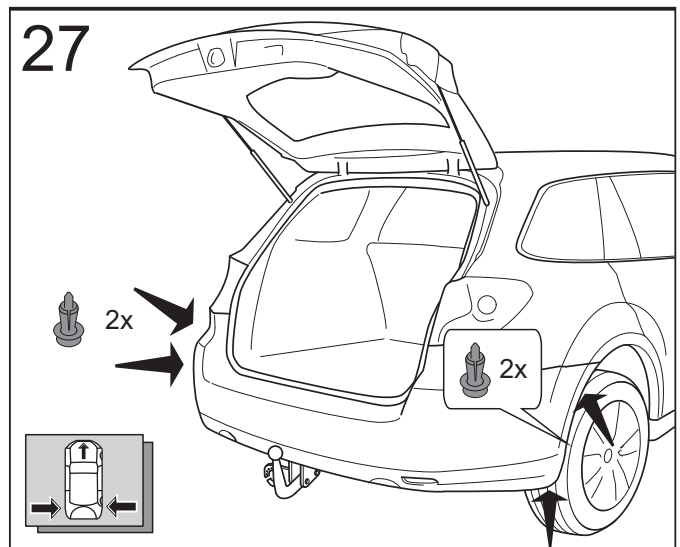
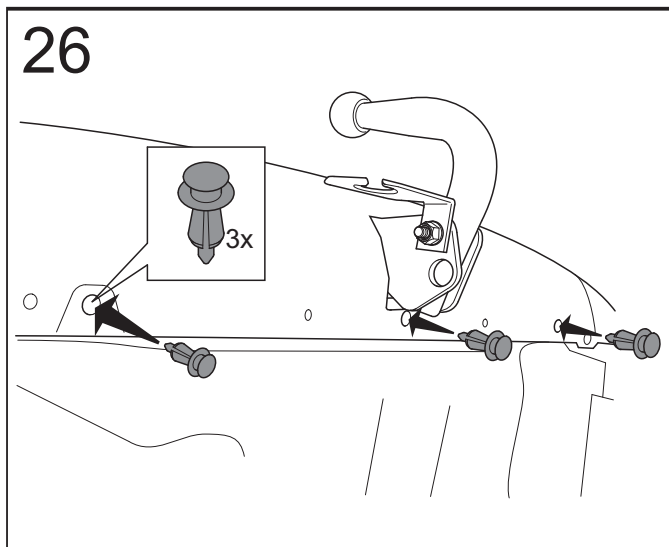
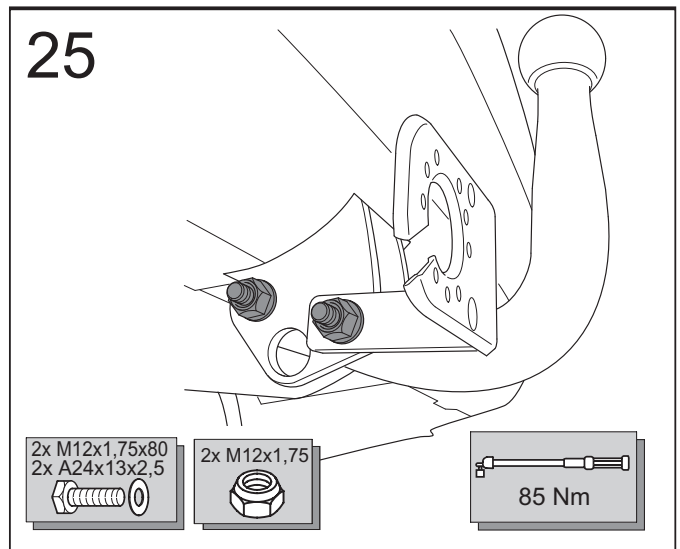
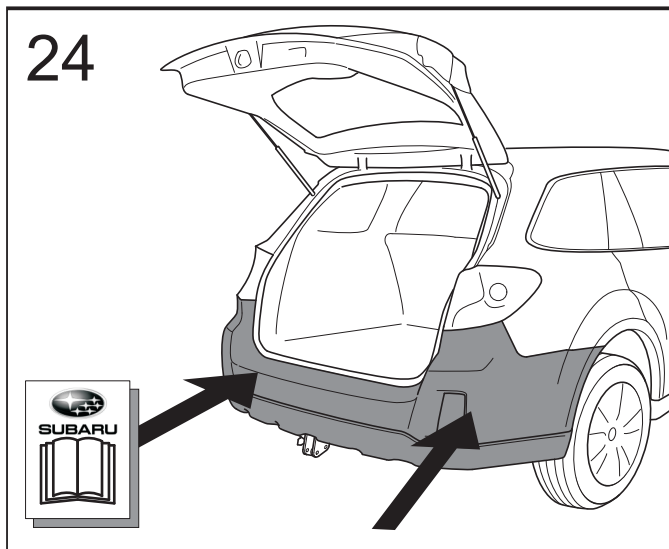
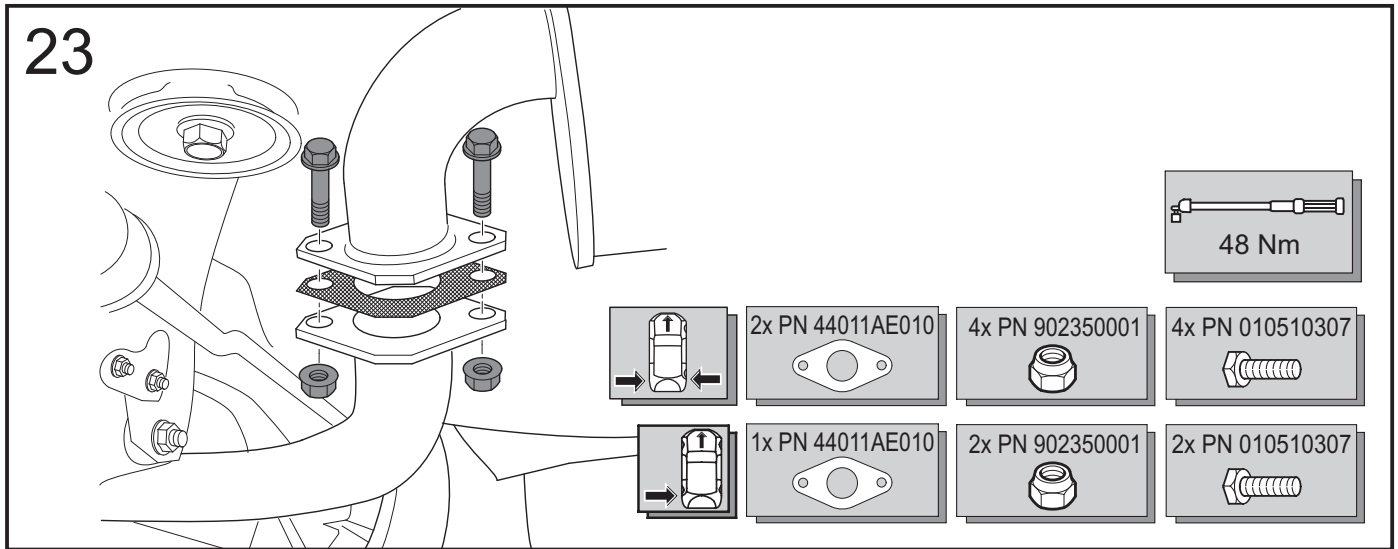



SUBARU

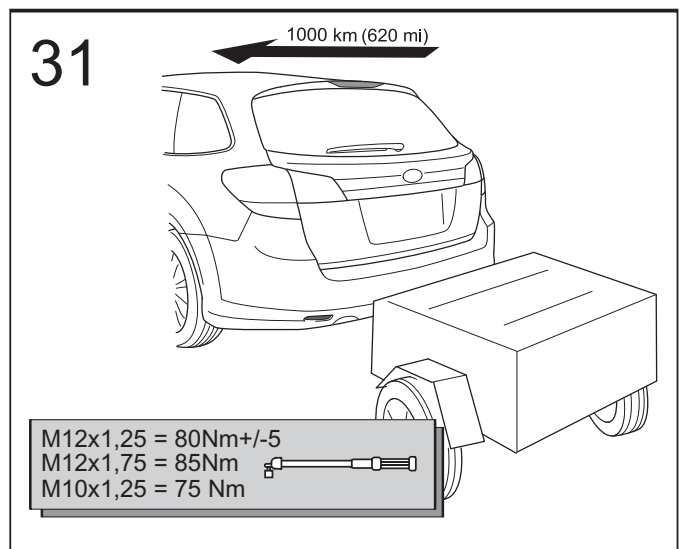
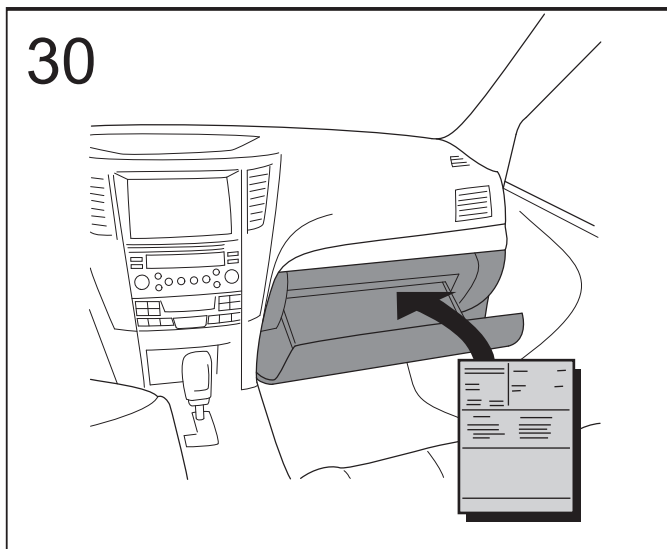
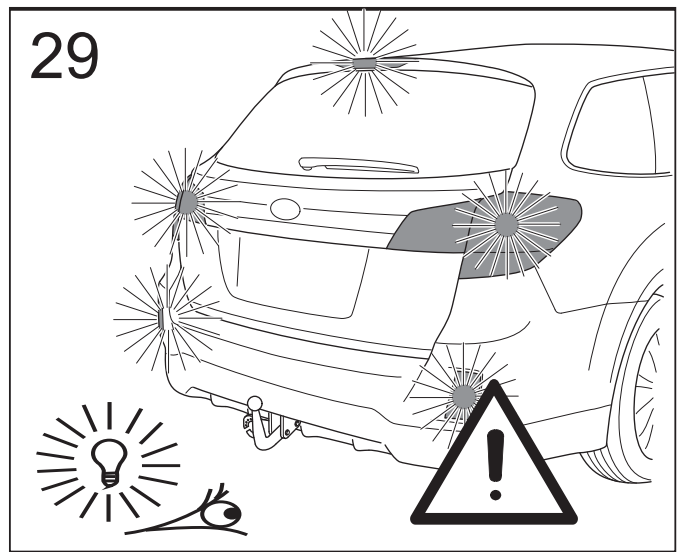
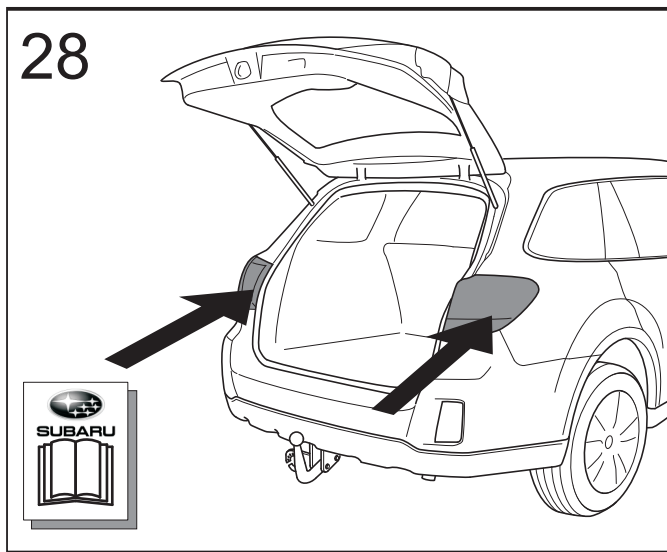

GB INSTRUCTIONS:

- Do not forget the washers.
- Retighten all mounting bolts after the trailer hitch has been in use for approx. 620 mi (1000 km). (observe correct tightening torque!)
- The coupling ball must be kept clean and greased.
- Install the electrical system in accordance with all pertinent regulations.
- The maximum permissible towed weight is specified in your vehicle registration papers.
- If the weight of the vehicle changes, it may be necessary to recalculate the maximum permissible towed weight from the D-value. For further information, consult your specialist dealer or vehicle inspection office.
- This trailer hitch has been tested in accordance with European Directive 94/20/EC. The test number is located on the rating plate. It is not necessary to mark the approval number directly on the trailer hitch.
- These installation instructions are an official document and an integral part of the trailer hitch. They must be kept safely and handed over with the vehicle if sold.
- SUBARU accepts no liability for product defects caused by the vehicle owner or other persons and/or incorrect use.



SUBARU

D HINWEISE:

- Unterlegscheiben nicht vergessen.
- Alle Befestigungsschrauben nach ca. 1000 km Anhängerbetrieb nachziehen. (Anzugsdrehmoment beachten!)
- Kupplungskugel sauber halten und fetten.
- Elektrische Anlage vorschriftsmäßig installieren.
- Die höchstzulässige Anhängelast finden Sie in ihren Fahrzeugunterlagen.
- Bei Änderungen des Fahrzeuggewichts muss die höchstzulässige Anhängelast gegebenenfalls aus dem D-Wert errechnet werden. Auskünfte gibt ihr Fachhändler oder die amtliche Prüfstelle.
- Diese Anhängenzugvorrichtung ist nach Richtlinie ECC 94/20 geprüft. Die Prüfnummer befindet sich auf dem Typenschild. Die Markierung der Homologationsnummer direkt an der Anhängenzugvorrichtung entfällt.
- Diese Einbauanleitung ist ein offizielles Dokument und Bestandteil der Anhängenzugvorrichtung. Sie muss aufbewahrt und bei Veräußerung des Fahrzeugs mitgegeben werden.
- SUBARU übernimmt keine Haftung für Produktmängel, die durch den Fahrzeughalter oder andere Personen und/oder unsachgemäße Verwendung verursacht wurden.

F REMARQUES :

- Ne pas oublier les rondelles.
- Au bout d'environ 1000 kilomètres de remorquage, resserrer toutes les vis de fixation. (respecter le couple de serrage !)
- La boule d'attelage doit être maintenue propre et il faut la graisser.
- Le système électrique doit être installé conformément aux prescriptions.
- La charge remorquée maximum autorisée est spécifiée dans la documentation de votre véhicule.
- En cas de modification du poids du véhicule, calculer, le cas échéant, la charge remorquée maximum autorisée à partir de la valeur D. Pour plus d'informations, veuillez consulter votre marchand spécialisé ou le centre de contrôle technique homologué.
- Ce dispositif de remorquage est contrôlé conformément à la directive 94/20/CE. Le numéro de contrôle se trouve sur la plaque signalétique. Il n'est pas nécessaire de marquer le numéro d'homologation directement au dispositif de remorquage.
- Ces instructions de montage sont un document officiel et font partie du dispositif de remorquage. Elles doivent être gardées dans un endroit sûr et être transmises si le véhicule est vendu.
- SUBARU décline toute responsabilité en cas de défauts de produits causés par le propriétaire du véhicule ou d'autres personnes et/ou par une utilisation inadéquate.

I AVVERTENZE:

- Non dimenticare le rondelle.
- Stringere tutte le viti di fissaggio dopo circa 1000 km di marcia con il rimorchio. (osservare la corretta coppia di serraggio!)
- Mantenere sempre pulita e ingrassata la sfera del gancio.
- Installare l'impianto elettrico secondo le norme vigenti per la circolazione stradale.
- La massa rimorchiabile massima consentita è riportata nel libretto di circolazione dell'autoveicolo.
- In caso di modifica del peso del veicolo trainante occorre calcolare il carico massimo ammesso per il rimorchio, eventualmente in base al valore D (valore al timone). Per informazioni rivolgersi al proprio concessionario o alla Motorizzazione civile.
- Il presente dispositivo di traino è omologato a norma 94/20/CE. Il codice di omologazione è riportato sulla targhetta dei dati tecnici. Non è richiesta la stampiglia dell'omologazione direttamente sul dispositivo di traino.
- Questo manuale di istruzioni per il montaggio è un documento ufficiale e parte integrante del dispositivo di traino. Deve essere conservato e consegnato al nuovo proprietario in caso di vendita del veicolo.
- SUBARU declina ogni responsabilità per vizi del prodotto imputabili al proprietario del veicolo o ad altre persone e/o ad un utilizzo improprio.