

MAZDA

GB REAR SPOILER Installation Instructions	N SPOILER BAK Monteringsveiledning
D SPOILER HINTEN Einbauanleitung	S SPOILER BAK Monteringsanvisning
E SPOILER TRASERO Instrucciones de Montaje	SF TAKASPOILERI Asennusohje
F PARE-CHOC'S ARRIÈRE Instructions de Montage	CZ ZADNÍ SPOILER Návod k Montáži
I SPOLIER POSTERIORE Istruzioni di Montaggio	H HÁTSÓ SPOILER Beszerelési Utasítása
P SPOILER TRASEIRO Instruções de Montagem	PL SPOILER TYLNY Instrukcja Instalowania
NL SPOILER ACHTER Inbouw-Instructie	GR ΣΠΟΙΛΕΡ ΠΙΣΩ Οδηγίες Τοποθέτησης
DK SPOILER BAG Monteringsveiledning	RU Задний спойлер крыши Инструкции по установке

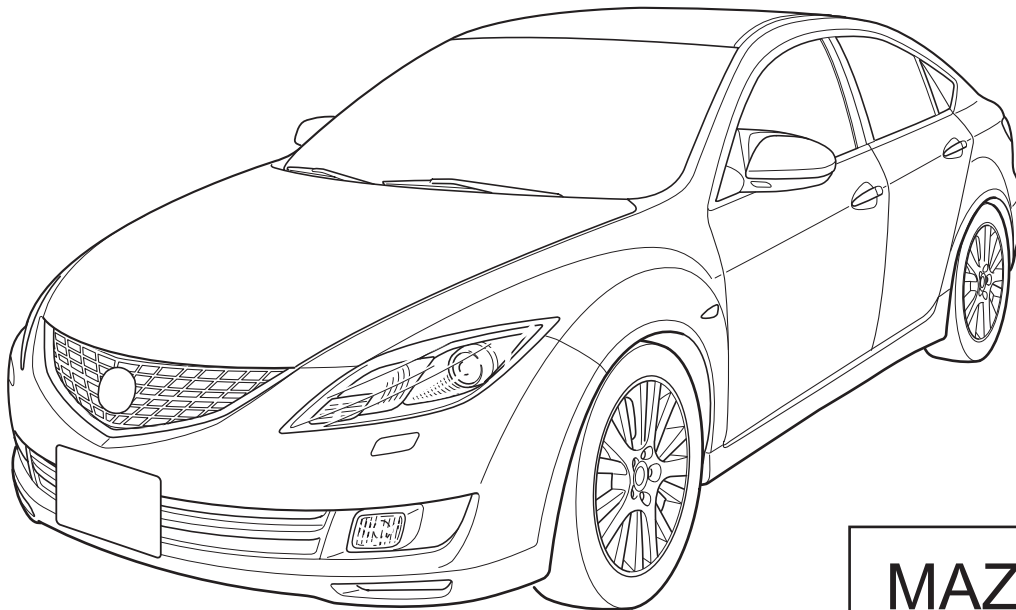

MAZDA 6

Part No: **GS1M V4 920F**

Date: 29-10-2007

© Copyrights MAZDA / MAZDA ACE

Sheet 1 of 9

Expert Fitment Required
Montage durch Fachwerkstatt erforderlich
Montaje sólo por el concesionario
Montage par spécialiste nécessaire
E necessario in officina specializzata
Especialista em montagem requerido
Montage door vakman nodig
Montage ved professionelt værksted påkrævet
Nødvendig med montering fra fagvevverksted
Verkstadsmontage erfordras
Asennus tarpeen merkkikorjaamossa
Montáž ve specializované dílně nutná
A szereléshez szakműhely kell
Konieczny montaż przez warsztat specjalistyczny
Να τοποθετεί από συνεργείο
Необходима подгонка специалистом

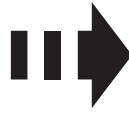

L+R

- (GB) Position arrow
- (D) Positionspfeil
- (E) Flecha de posición
- (F) Flèche de position
- (I) Freccia di posizione
- (P) Flexa de posição
- (NL) Lokatie/Positie pijl
- (DK) Lokaliseringspil
- (N) Posisjonspil
- (S) Positionpil
- (SF) Paikannusnuoli
- (CZ) Šipka na pozici
- (H) Helyzetjelző nyíl
- (PL) Strzałka położenia
- (GR) Βέλος θέσης
- (RU) Стрелка расположения

- (GB) Movement arrow
- (D) Bewegungspfeil
- (E) Flecha de movimiento
- (F) Flèche de mouvement
- (I) Freccia di movimento
- (P) Flexa de movimento
- (NL) Richtingspijl
- (DK) Bevægelsespil
- (N) Bevegelsespil
- (S) Rörelsepil
- (SF) Liikesuuntanuoli
- (CZ) Šipka pohybu
- (H) Mozgásirányjelző nyíl
- (PL) Strzałka kierunku ruchu
- (GR) Βέλος κίνησης
- (RU) Стрелка движения

- (GB) Same procedure for the left and right side
- (D) Gleicher einbau für linke und rechte seite
- (E) Mismo procedimiento para lado izquierdo y derecho
- (F) Procédure identique pour les côtés gauche et droit
- (I) Stessa procedura valida per il lato destro e sinistro
- (P) Mesmo procedimento para o lado esquerdo e direito
- (NL) Dezelfde procedure voor de linker en rechter zijde
- (DK) Samme fremgangsmåde for venstre og højre side
- (N) Samme prosedyre for venstre og høyre side
- (S) Samma åtgärd för vänster och höger sida
- (SF) Samat toimenpiteet vasemmalle ja oikealle puolelle
- (CZ) Postup je stejný pro levou i pravou stranu
- (H) Az eljárás azonos a bal és a jobb oldalon
- (PL) Te same czynności należy wykonać po lewej i prawej stronie
- (GR) Ίδια διαδικασία για την αριστερή και τη δεξιά πλευρά
- (RU) Однаковая последовательность действий как для левой, так и для правой стороны



- (GB) Tape up
- (D) Mit klebeband befestigen
- (E) Fijar con cinta adhesiva
- (F) Fixer avec ruban adhésif
- (I) Fissare con nastro adesivo
- (P) Sujeitar com fita adesiva
- (NL) Vastzetten met tape
- (DK) Fastgøres med tape
- (N) Fest fast med klebeband
- (S) Fästet med tejp
- (SF) Kiinnytys teipillä
- (CZ) Upevnit lepicí páskou
- (H) Rögzítse ragasztószalaggal
- (PL) Umocować taśmą samoprzylepną
- (GR) Στερέωση με κολλητική ταινία
- (RU) Закрепите клейкой лентой

- (GB) Wipe clean
- (D) Reinigen
- (E) Limpiar
- (F) Nettoyer
- (I) Ripulire
- (P) Limpiar
- (NL) Zuiver maken
- (DK) Aftørring
- (N) Rengjøring
- (S) Rengör
- (SF) Puhdista
- (CZ) Očistit
- (H) Tisztítsa meg
- (PL) Oczyszczyć
- (GR) Καθάρισμα
- (RU) Протрите дочиста

- (GB) Throw away
- (D) Entsorgen
- (E) Tratamiento de residuos
- (F) Rebuter
- (I) Smaltire
- (P) Eliminar
- (NL) Weggoeien
- (DK) Affald
- (N) Avskaffe
- (S) Ta hand om avfallet
- (SF) Hävittää
- (CZ) Vyhodit
- (H) Távolítsa el
- (PL) Usunąć jako odpad
- (GR) Απρόσυρη
- (RU) Выбросите



- (GB) Warning
- (D) Achtung
- (E) Atención
- (F) Attention
- (I) Attenzione
- (P) Atenção
- (NL) Let op
- (DK) Bemærk
- (N) Pass på
- (S) Varning
- (SF) Huomio
- (CZ) Pozor
- (H) Figyelem
- (PL) Uwaga
- (GR) Προσοχή
- (RU) Осторожно

- (GB) Use cenyre punch
- (D) Körmn
- (E) Marcar destornillador
- (F) Marquer au pointeau
- (I) Bulinare
- (P) Marcar con punção de
- (NL) Marcar
- (DK) Centerpønsen
- (N) Ørnmærkning med kørner
- (S) Körning
- (SF) Märkning med körnslag
- (CZ) Merkitse puikolla
- (H) Dűlkövat
- (PL) Kipontozni punktowac
- (GR) Ποντάρισμα
- (RU) Используйте кернер

- (GB) Use drill
- (D) Bohrer verwenden
- (E) Utilizar broca
- (F) Utiliser une mèche
- (I) Utilizzare trapano
- (P) Utilizar a perfuradora
- (NL) Boordiameter
- (DK) Bor anvendes
- (N) Bruk diameter
- (S) Använd borrh
- (SF) Käytä poraa
- (CZ) Použit vrták
- (H) Használjon fúrot
- (PL) Stosować wiertarkę
- (GR) Χρησιμοποιείτε τρυπάνι
- (RU) Используйте дрель



- (GB) Burr removal
- (D) Entgraten
- (E) Desbarbar
- (F) Ebarber
- (I) Sbavare
- (P) Rebarbar
- (NL) Ontbramen
- (DK) Afgratning
- (N) Fjerning av spon
- (S) Avgrada
- (SF) Purseen poisto
- (CZ) Odstranit ořtepy
- (H) Sorjätlanítás
- (PL) Usunąć zadziory
- (GR) Αφαιρείτε τα γρέζια
- (RU) Снятие заусенцев

- (GB) Apply rust proof paint
- (D) Gegen korrosion schützen
- (E) Proteger contra la corrosión
- (F) Protéger contre la corrosion
- (I) Proteggere dalla corrosione
- (P) Proteger contra corrosão
- (NL) Beschermen tegen roest
- (DK) Beskyt mod korrosion
- (N) Beskytt mot korrosjon
- (S) Skydda mot korrosion
- (SF) Suojaa korroosiota vastaan
- (CZ) Chránit proti korozi
- (H) Védje korrózió ellen
- (PL) Chronić przed korozją
- (GR) Αντιδιαβρωτική προστασία
- (RU) Нанесите антикоррозийную краску

- (GB) See text
- (D) Siehe textt
- (E) Véase texto
- (F) Voir text
- (I) Vedi testo
- (P) Cf. o texto
- (NL) Zie tekst
- (DK) Se teksten
- (N) Se tekst
- (S) Se text
- (SF) Katso teksti
- (CZ) Viz text
- (H) Lásd a zsvövegben
- (PL) Patrz tekst
- (GR) Βλέπε κείμενο
- (RU) См. текст

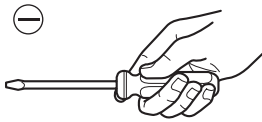

PRIMER

- (GB) Use flat-blade screwdriver
- (D) Einen flachen schraubendreher verwenden
- (E) Use destornillador de punta plana
- (F) Utiliser un tournevis à tête plate
- (I) Utilizzare un cacciavite a testa piatta
- (P) Utilizar chave de fendas
- (NL) Gebruik een platte schroevendraaier
- (DK) Brug en fladhovedet skruetrækker
- (N) Bruk flathodet skrutrekker
- (S) Använd en platt skruvmejsel
- (SF) Käytä litteäteräistä ruuviavainta
- (CZ) Použijte šroubovák s plochou hlavou
- (H) Használjon lapos fejű csavarhúzó
- (PL) Używać śrubokrętu z płaską końcówką
- (GR) Χρησιμοποιήστε καταβίδι επίπεδης κεφαλής
- (RU) Используйте отвертку с плоским жалом

- (GB) Temporarily tightening
- (D) Provisorisch festziehen
- (E) Apretar temporariamente
- (F) Serrage provisoire
- (I) Per stringere temporaneamente
- (P) Apertar temporariamente
- (NL) Provisorisch vastdraaien
- (DK) Midlertidig stramning
- (N) Midlertidig stramning
- (S) Tillfällig fastdragning
- (SF) Tilapäinen kiristys
- (CZ) Přečhodné utažení
- (H) Ideiglenes meghúzás
- (PL) Dokręcenie tymczasowe
- (GR) Προσωρινό βίδωμα
- (RU) Временное затягивание

- (GB) Primer coating
- (D) Grundierungsschicht
- (E) Capa de imprimación
- (F) Couche d'apprêt
- (I) Mano di fondo
- (P) Revestimento primário
- (NL) Primerlaag
- (DK) Tipper bestrygning
- (N) Påføring av primer
- (S) Stryk på grundbelägning
- (SF) Pohjaväriin päällystys
- (CZ) Podkladový nátěr
- (H) Alapozó bevonat
- (PL) Pierwsza warstwa
- (GR) Επίστρωση ασταρίου προεργασίας
- (RU) Слой грунтовки

A

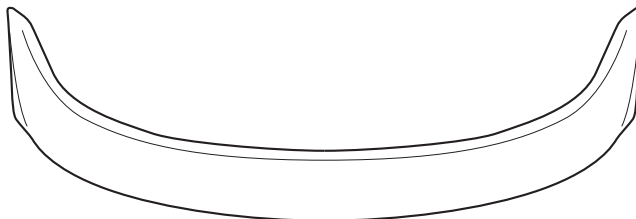

X 1

B

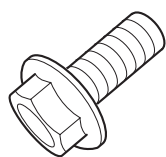

[9YA02 0631]

X 4

C

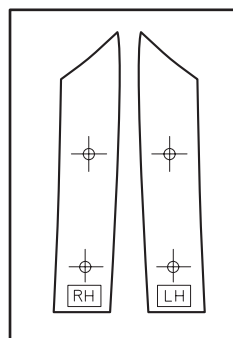

X 1

D

(LH)

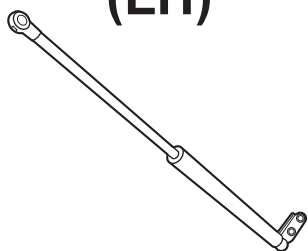

[GS1N 63620]

X 1

E

(RH)

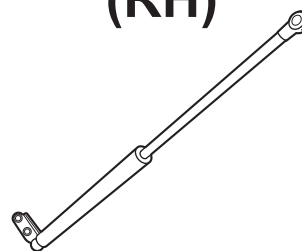

[GS1N 62620]

X 1

F

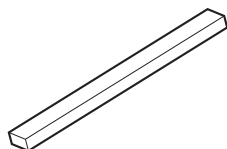

X 2

G

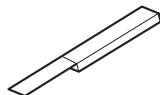

L=30mm

X 2

H

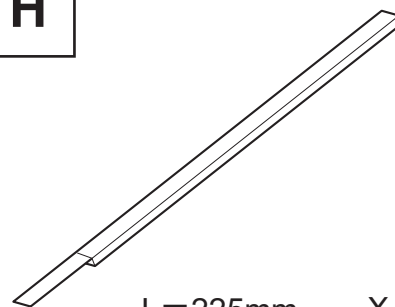

L=225mm

X 2

I

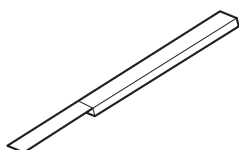

L=63mm

X 2

J



X 4

1

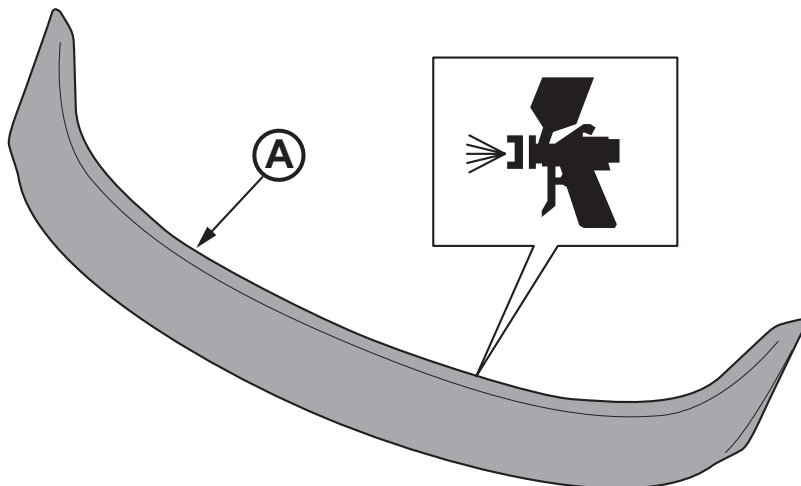

2

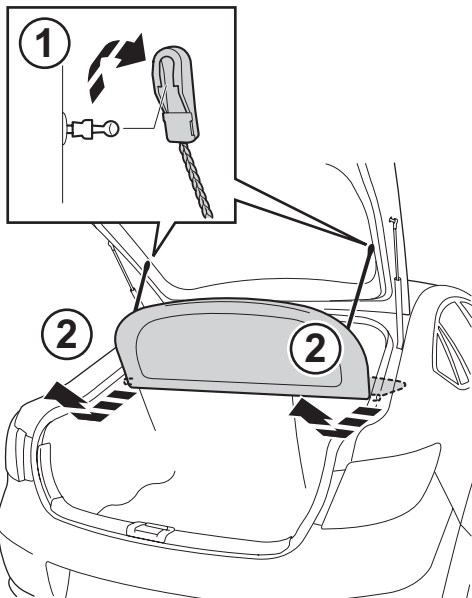

3

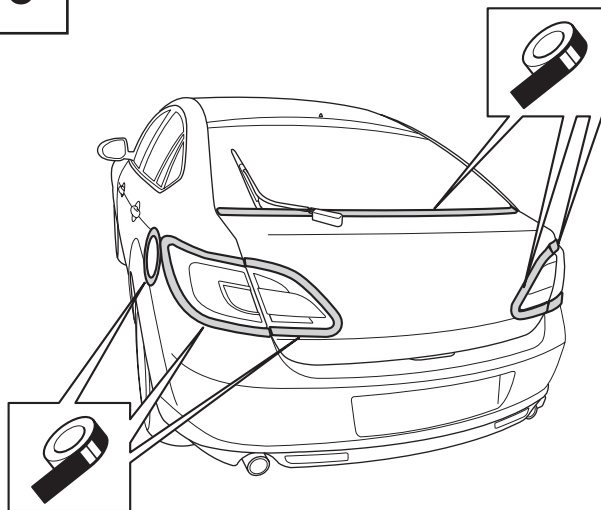

4

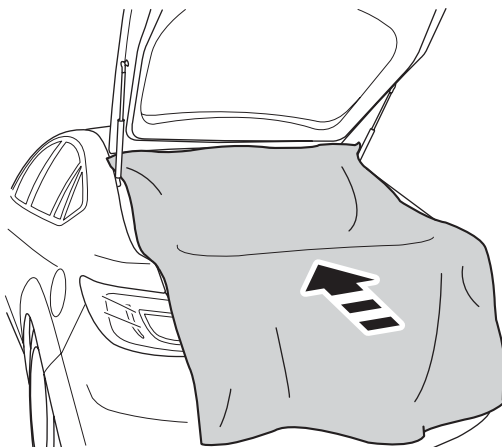

5

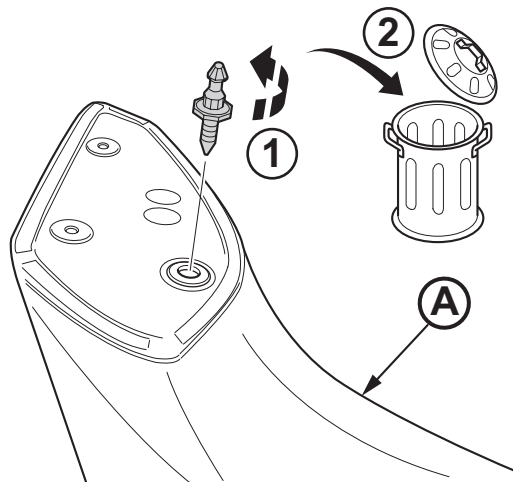

6

L+R

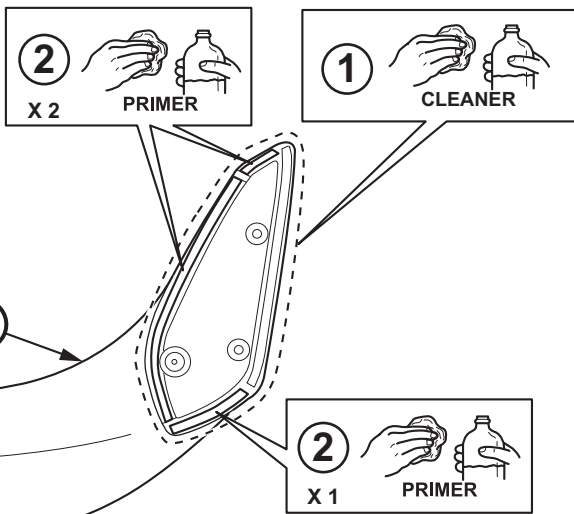

7

L+R

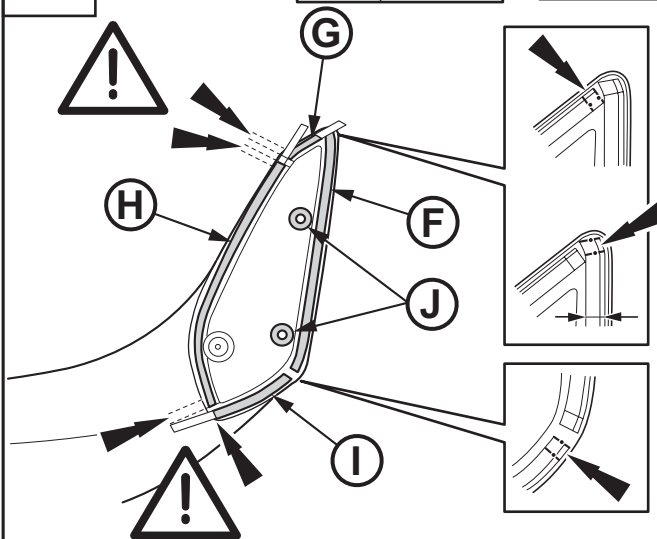

8

L+R

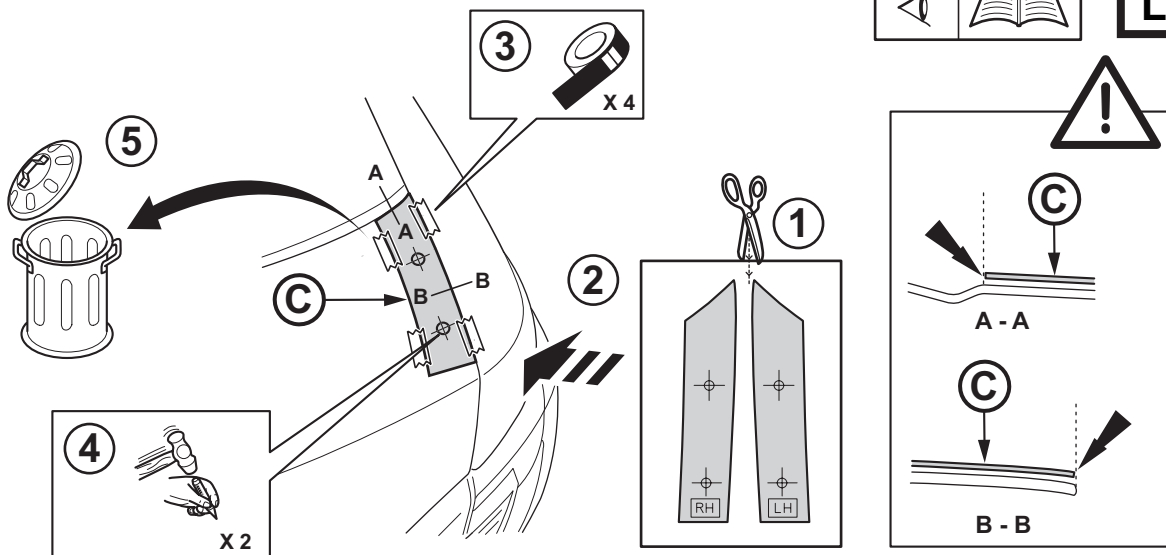

9

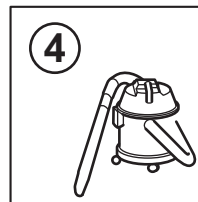
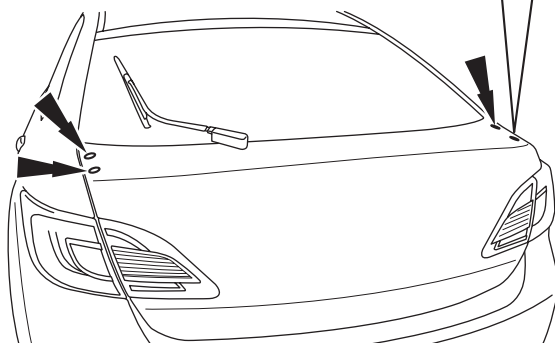
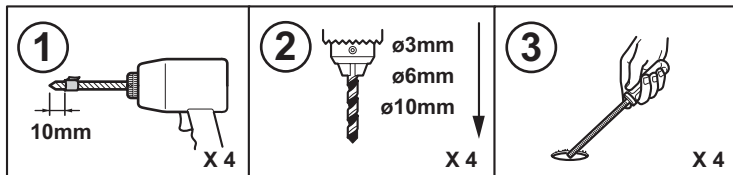

10

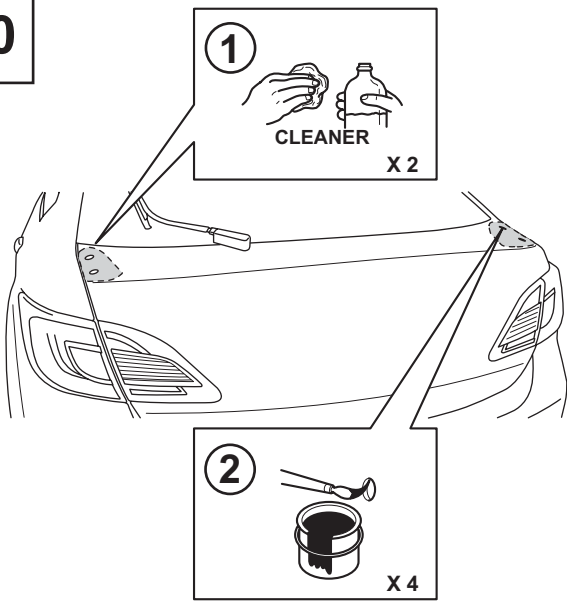

11



12

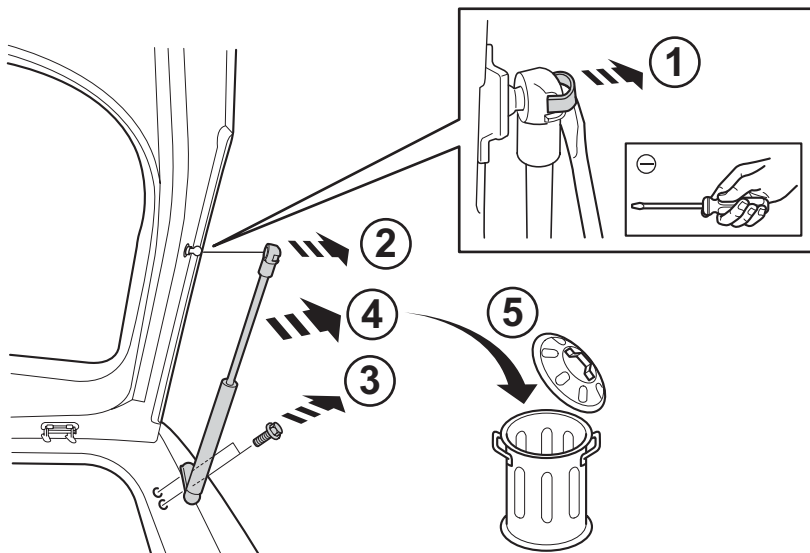

L+R

13

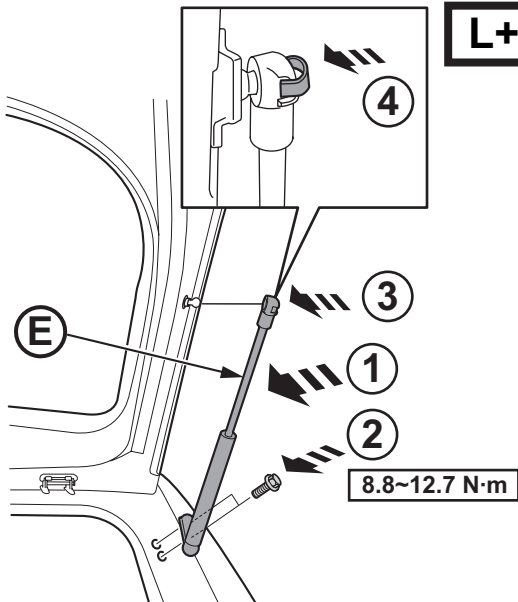

L+R

14

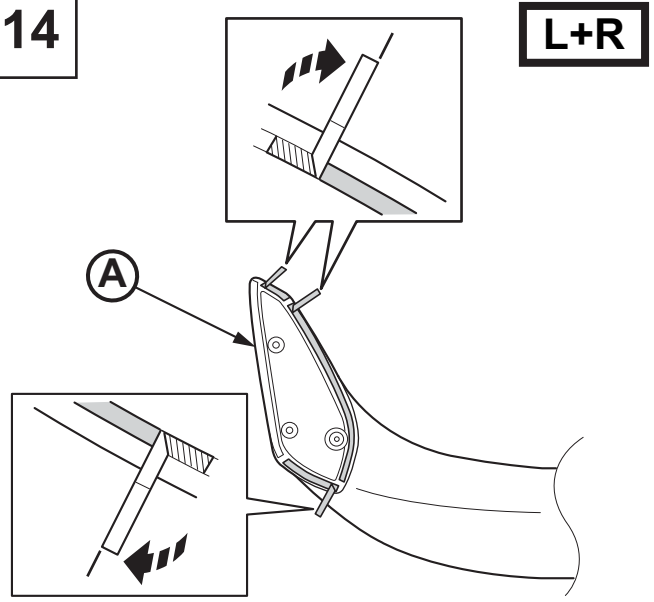

L+R

15

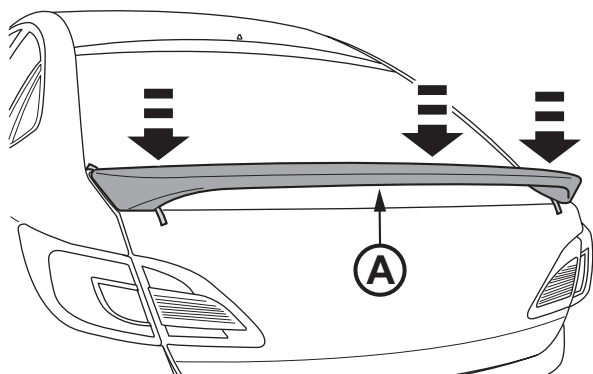

16

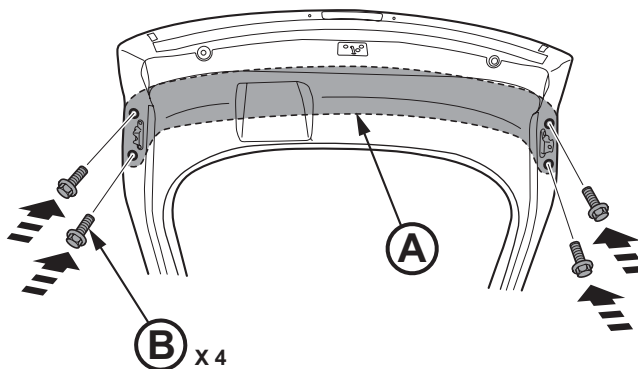

17

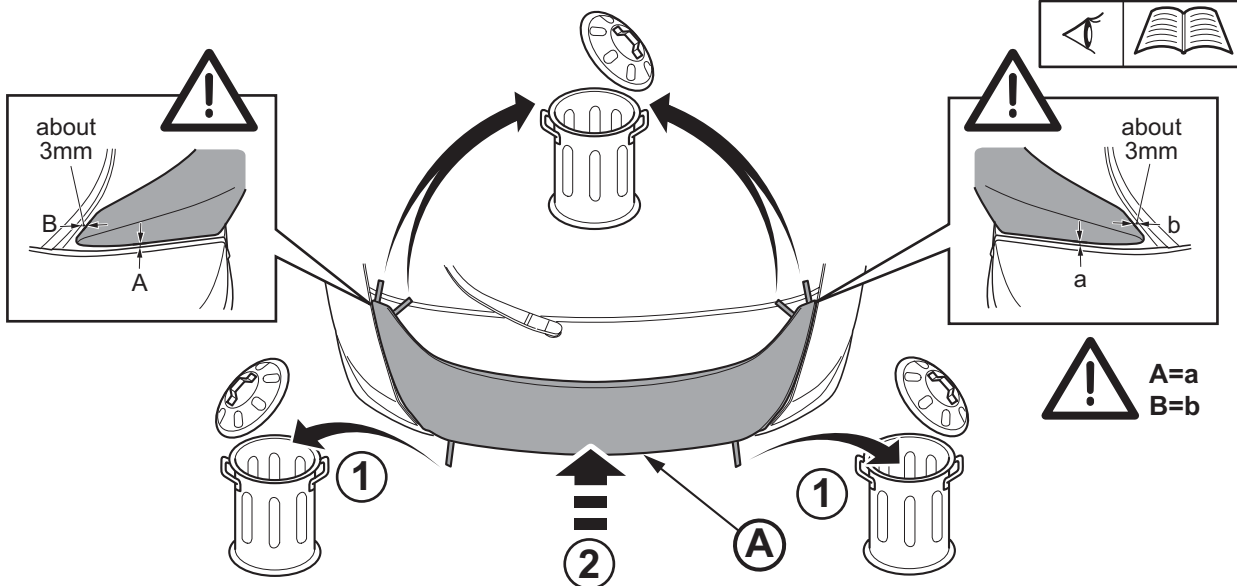

18

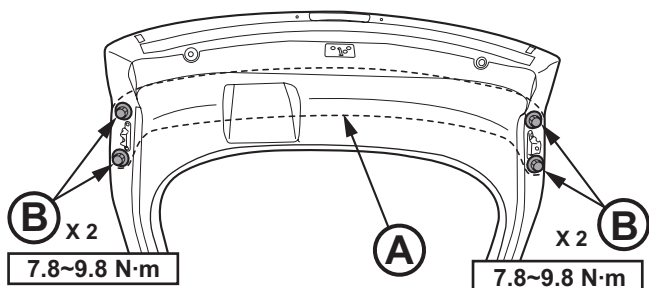

19

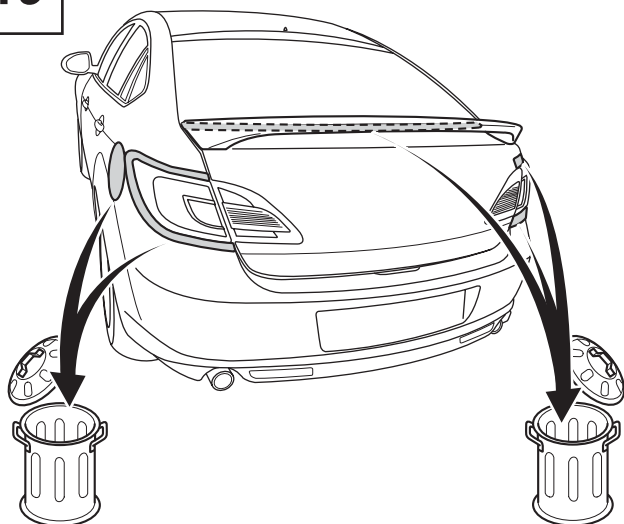

20

