

GENUINE FRONT MUD FLAP

INSTALLATION INSTRUCTIONS

VEHICLE: CX-7
PART NUMBER: EG21 V3 450F

Thank you for purchasing a genuine MAZDA accessory.

Please read the contents of this booklet in order to properly install and use the front mud flap. Your safety depends on it.

Keep these instructions with your vehicle records for future reference.

【 ⚠ WARNING】

- There are several **⚠ WARNING** and **⚠ CAUTION** sections in this booklet concerning safety when installing or removing the front mud flap. Always read and follow them in order to prevent injuries, accidents, and possible damage to the vehicle.

⚠ WARNING: Indicates a situation in which serious injury or death could result if the warning is ignored.

⚠ CAUTION: Indicates a situation in which bodily injury or damage to the vehicle could result if the caution is ignored.

- Do not modify the front mud flap.
- Do not install the front mud flap in any way other than described in the following instructions.
- If in any doubt, please ask your MAZDA dealer to install the accessory in order to prevent errors in installation.
- If you have any questions about the use of the accessory, ask your MAZDA dealer for proper advice before using it.
- MAZDA and its suppliers are not responsible for injuries, accidents, and damage to persons and property that arise from the failure of the dealer or installer to follow these instructions.
- To ensure safety and reliability of the work, installation, removal and disposal work must be carried out by an Authorized MAZDA dealer shop.

NOTE

To the dealer

Please turn over these instructions to the customer after installation.

To the customer

- Keep these instructions after installation. The instructions may be necessary for installing other optional parts or removal of this accessory.
- Should the vehicle or this accessory be resold, always leave these instructions with it for the next owner.

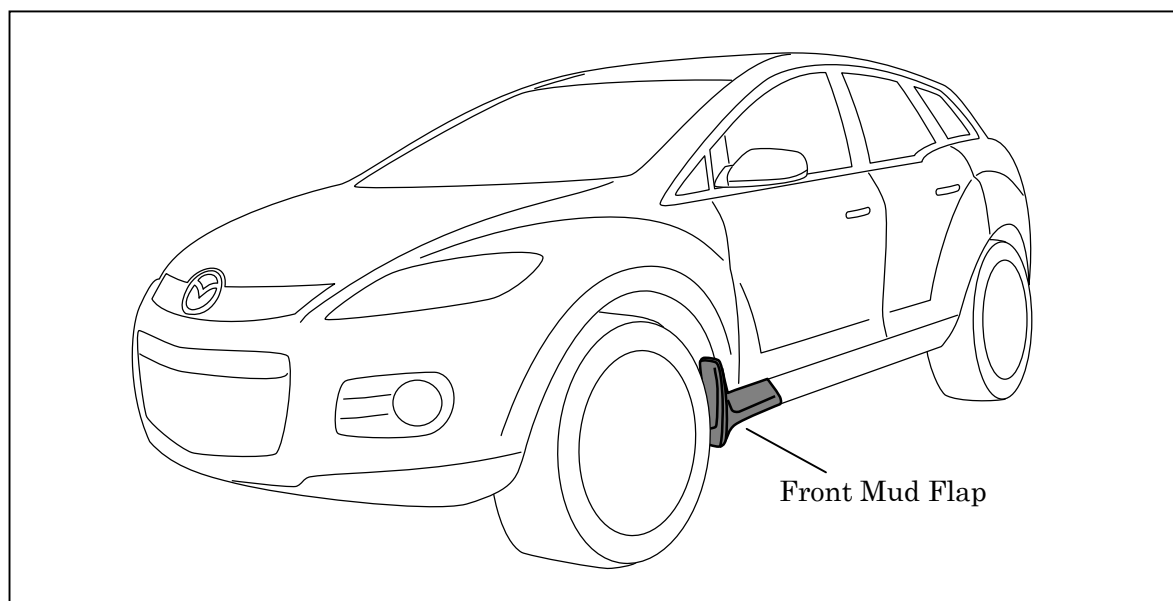

1. COMPLETED CHART



2. PARTS

⚠ NOTE

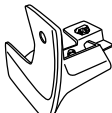
- Before installation, verify that the kit includes all the following parts and that parts are not dirty, scratched, or damaged.

No.	Part No.	Part Name	Fig.	Qty.
①	EG21 V3 451/452	Front Mud Flap (RH/LH)		1 ea.
②	—	Installation Instruction		1

3. REQUIRED TOOLS

- ☆ Phillips screwdriver
- ☆ Flathead screwdriver
- ☆ Fastener remover
- ☆ Nipper
- ☆ Masking tape

4. BEFORE INSTALLATION

⚠ WARNING

- Park the vehicle on a flat surface, set the transmission lever at “P” range, block the tires, and set the parking brake firmly before performing work.

⚠ CAUTION

- Use a mat or protector while you remove and install the vehicle parts.
The body may be scratched or dirty.
- Removed parts and kit parts should be placed on the protection sheet so that parts will not be scratched or damaged.

REFERENCE

- Refer to the Workshop Manual for removal and installation of vehicle parts.
- For the installation of RH parts, follow the instructions shown as that of LH parts.

5. REMOVAL OF FRONT SIDE STEP MOLDING

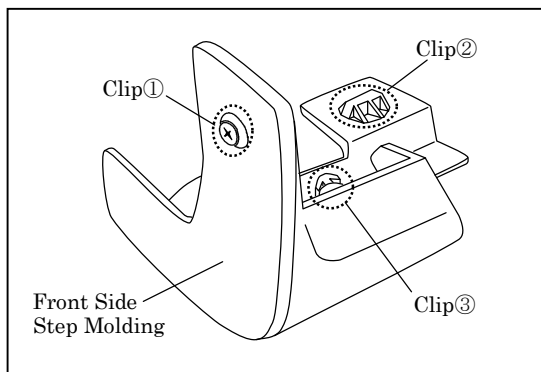

* Assembled shape of
the front side step molding *

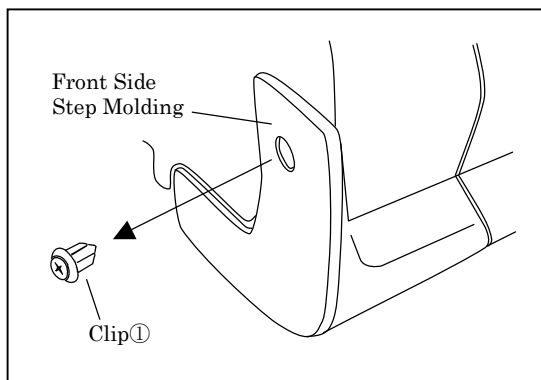

1. Remove clip ① with a Phillips screwdriver.

⚠ CAUTION

- Remove clip ① carefully not to damage it.
Keep it for the installation of the front mud flap.

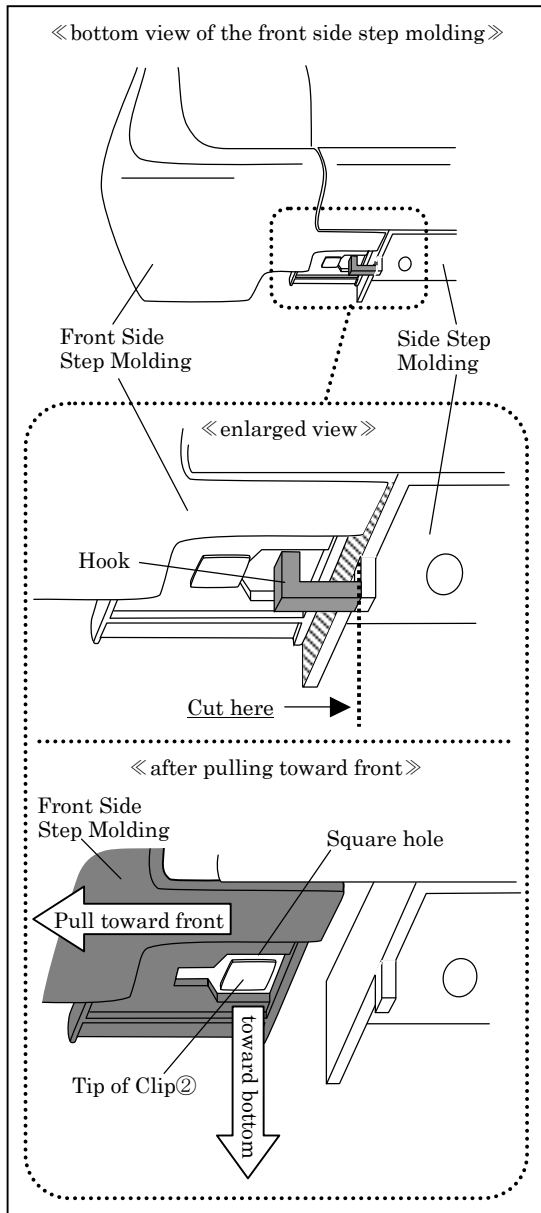

2. Cut out the hook of the side step molding with a nipper as shown in the enlarged view.

3. Pull the front side step molding toward front, fit the square hole over the tip of clip②, and remove the front side step molding from clip② pulling it toward bottom.
(Clip② remains on the body.)

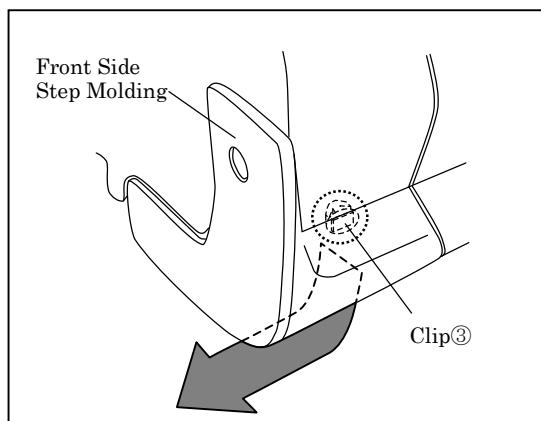

4. Remove the front side step molding from clip③ and body pulling it toward bottom and toward front.
(Clip③ remains on the body.)

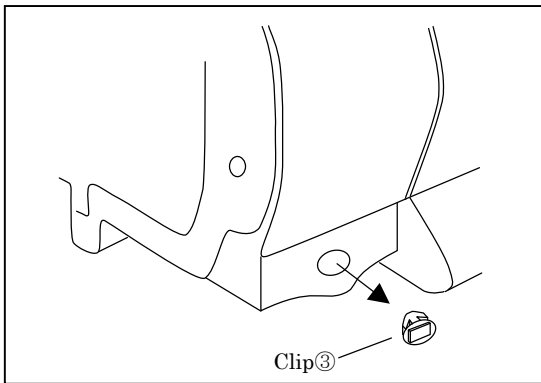

5. Remove clip③ from the body by using a fastener remover.

⚠ CAUTION

•If the shape of the hole in which clip is installed changes while removing clip③, fix the shape in order to install front mud flap correctly.

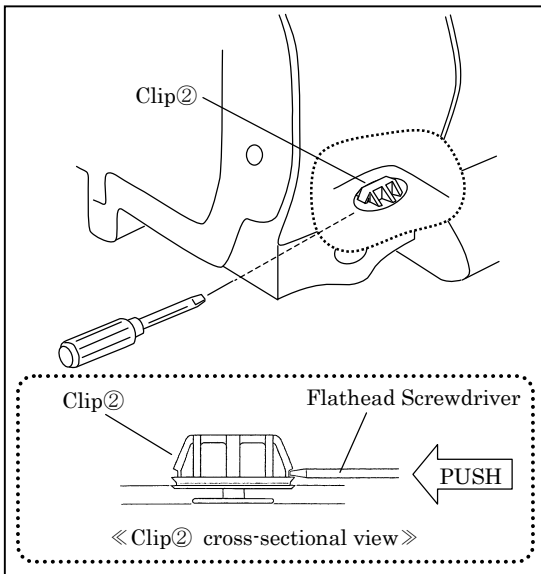

6. Set the tip of a flathead screwdriver on the side of clip②. (see the cross-sectional view) Push the tab of clip② and remove it from the body.

⚠ CAUTION

•If the shape of the hole in which clip is installed changes while removing clip②, fix the shape in order to install front mud flap correctly.

6. INSTALLATION OF FRONT MUD FLAP

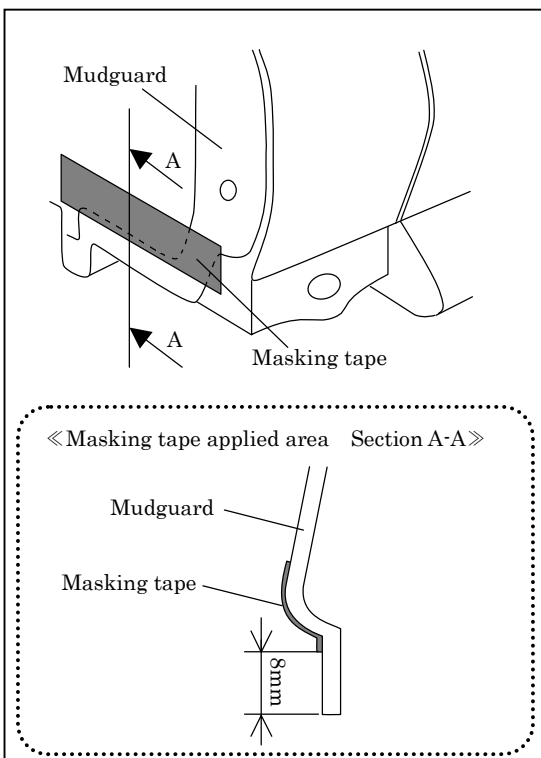

7. Apply a piece of masking tape at 8 mm away from the bottom end of the mudguard as shown in the left figure.

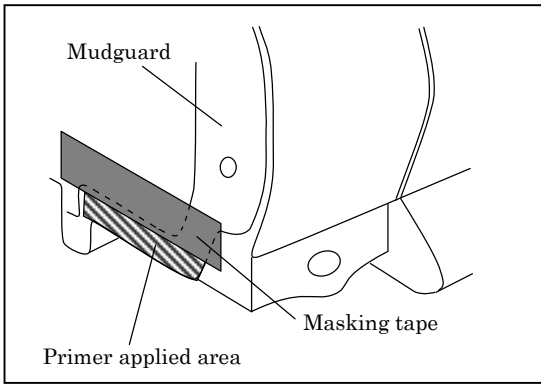

8. Put primer on the surface of the mudguard beneath the masking tape as shown in the left figure.

9. Remove the masking tape.

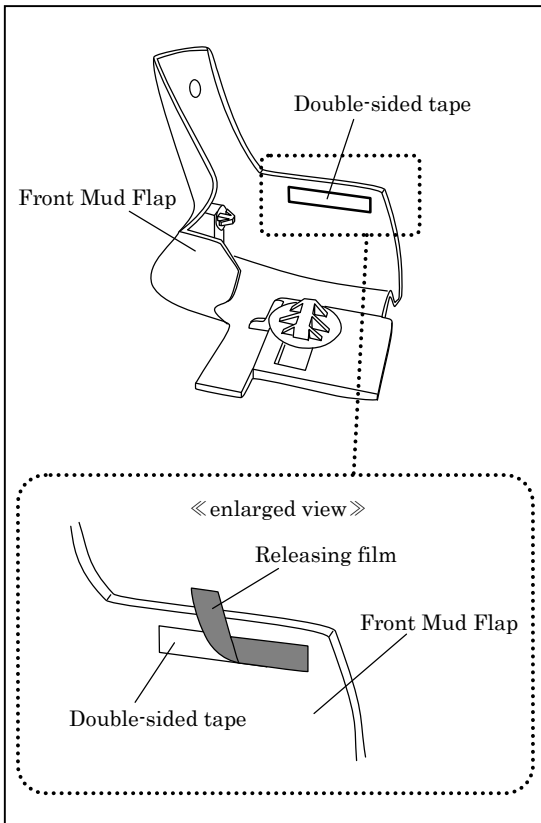

10. Peel off one end of the releasing film on the attached double-sided tape as shown in the left figure. Bend it upward to move its end outside of the front mud flap.

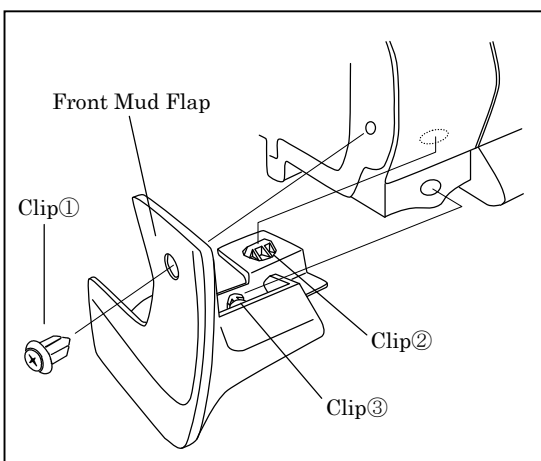

11. Install the front mud flap in order of clip③ and clip②.

12. Install clip① that is removed from the body.

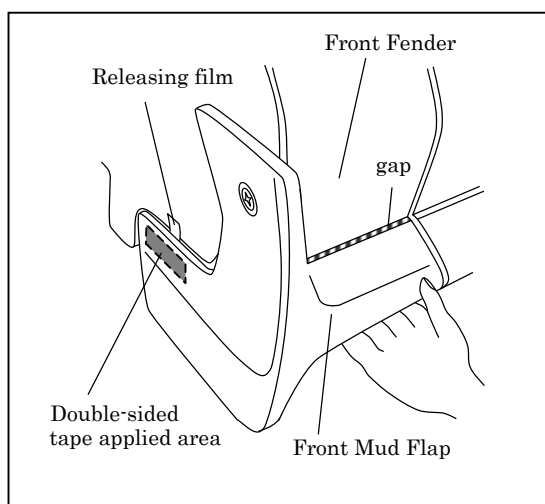

13. Lift up the front mud flap and make the gap between the front fender and the front mud flap constant from one end to another. While keeping the position, remove the releasing film and push the front mud flap toward the front fender in order to get good adhesion.

⚠ CAUTION

- Before installation of the front mud flap, wait at least 1 minute after putting the primer on the surface of the mudguard in order to confirm that the painted surface of mudguard becomes dry.
- Do not apply the double-sided tape under cold circumstances (below 15 degree C) in order to get strong adhesion. Also, warm up the mudguard and its surface above 15 degree C by using dryer. When warming it up, do not warm up the double-sided tape directly.

7. FRONT MUD FLAP PRECAUTIONS

⚠ CAUTION

- If gasoline, engine coolant, or battery fluid adheres to the painted surface of the resin parts, it will cause discoloration, stains, or paint peeling. Wipe it off with a soft cloth immediately.
- Don't drive through an automatic car wash ; it may damage the front mud flap.
- Don't use car polish containing wax compounds. Otherwise, the paint could be damaged.
- If the vehicle height is lowered due to the vehicle being at maximum passenger or cargo capacity, decrease the vehicle speed when parking on a road shoulder or entering/leaving a road shoulder or bump. Otherwise, the front mud flap could be damaged.

【For Authorized Dealer】

INSTALLATION INSPECTION SHEET

CX-7	Front Mud Flap
	EG21 V3 450F

A. Inspection items after installation

Inspect the installed/reinstalled parts for the following items.

Inspection Parts	Inspection Items (○)		
	Clearance/Fit	Scratches/Dirt	Installation/Tightening
Front Mud Flap	○	○	○
Front Fender	—	○	—

Front Mud Flap Installation Inspection					
Date , ,					
VIN.					
Approved		Checked		Person In Charge	

※The term of validity for this sheet : 12 months.