

MAZDA

GB	DAYTIME RUNNING LIGHTS Installation instruction
D	TAGFAHRLICHT Einbauanleitung
E	LUCES DE CIRCULACIÓN DIURNA Instrucciones de montaje
F	LUMIÈRES DE VEILLE EN JOURNÉE Notice de montage
I	LUCI DI MARCIADIURNA Istruzioni di montaggio
P	FARÓIS PARAUTILIZAÇÃO DURANTE O DIA Instruções de montagem
NL	DAGRIJLICHT Inbouw-instructie
DK	LYS PÅ KØRETØJ I DAGTIMERNE Monteringsvejledning

N	KJØRELYS Monteringsveiledning
S	VARSSELLJUS Monteringsanvisning
SF	PÄIVÄÄJOVALOT Asennusohje
CZ	DENNÍ SVĚTLA Návod k montáži
H	NAPPALI MENETFÉNY Beszerelési utasítás
PL	ŚWIATŁA DO JAZDY DZIENNEJ Instrukcja zabudowy
GR	ΦΩΤΑ ΠΟΡΕΙΑΣ ΗΜΕΡΑΣ Οδηγίες Τοποθέτησης
RU	ДНЕВНЫЕ ХОДОВЫЕ ОГНИ Инструкция по установке

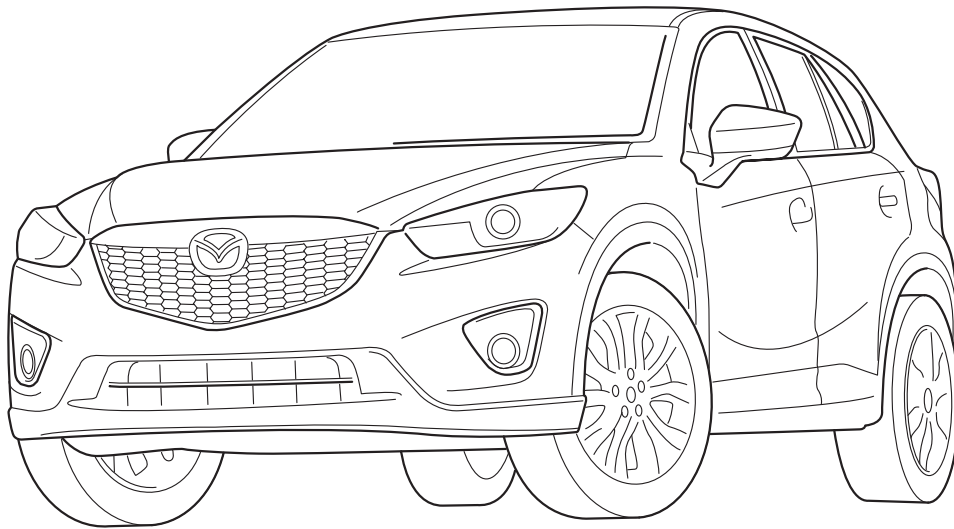

CX-5

KE

Part Number: KD45-V5-750A

Date: 24-04-2012

© Copyright MAZDA

Sheet 1 of 16

Expert Fitment Required
Montage durch Fachwerkstatt erforderlich
Montaje sólo por el concesionario
Montage par spécialiste nécessaire
E' necessario in officina specializzata
Especialista em montagem requerido
Montage door vakman nodig
Montage ved professionelt værksted påkrævet
Nødvendig med montering fra fagvejværksted
Verkstadsmontage erfordras
Asennus tarpeen merkkikorjaamossa
Montáž ve specializované dílně nutná
A szereléshez szakműhely kell
Konieczny montaż przez warsztat specjalistyczny
Να τοποθεί απο συνεργείο
Необходима установка специалистами

Mazda Color Table

	GB	D	E	F	I	P	NL	DK
L	Blue	Blau	Azul	Bleu	Blu	Azul	Blauw	Blå
B	Black	Schwarz	Negro	Noir	Nero	Preto	Zwart	Sort
BR	Brown	Braun	Marrón	Marron	Marrone	Castanho	Bruin	Brun
DL	Dark blue	Dunkelblau	Azul oscuro	Bleu foncé	Blu scuro	Azul-escuro	Donkerblauw	Mørkeblå
DG	Dark green	Dunkelgrün	Verde oscuro	Vert foncé	Verde scuro	Verde-escuro	Donkergroen	Mørkegrøn
G	Green	Grün	Verde	Vert	Verde	Verde	Greon	Grøn
GY	Grey	Grau	Gris	Gris	Grigio	Cinzeno	Grijs	Grå
LB	Light blue	Hellblau	Azul claro	Bleu clair	Blu chiaro	Azul-claro	Lichtblauw	Lyseblå
LG	Light green	Hellgrün	Verde claro	Vert clair	Verde chiaro	Verde-claro	Lichtgroen	Lysegrøn
N	Natural colour	Naturfarbe	Color natural	Nature	Colori naturali	Cores naturais	Naturel	Naturfarvet
O	Orange	Orange	Naranja	Orange	Arancione	Laranja	Oranje	Orange
P	Pink	Rosa	Rosa	Rose	Rosa	Rosa	Rosé	Rosa
R	Red	Rot	Rojo	Rouge	Rosso	Vermelho	Rood	Rød
PU	Purple	Purpur	Púrpura	Pourpre	Rosso porpora	Púrpura	Paars	Purpur
SB	Sky blue	Himmelblau	Azul cielo	Bleu ciel	Celeste	Azul-céu	Hemelsblauw	Himmelblå
T	Yellow brown	Gelbbraun	Amarillo-marrón	Marron-jaune	Giallomarrone	Castanho-amarelado	Geelbruin	Gulbrun
W	White	Weiß	Bianco	Blanc	Bianco	Branco	Wit	Hvid
Y	Yellow	Gelb	Amarillo	Jaune	Giallo	Amarelo	Geel	Gul
V	Violet	Violett	Violeta	Violet	Viola	Violeta	Violet	Violet

	N	S	SF	CZ	H	PL	GR	RUS
L	Blå	Blå	Sininen	Modrá	Kék	Niebieska	Μπλε	Синий
B	Sort	Svart	Musta	Černá	Fekete	Czarna	Μαύρο	Чёрный
BR	Brun	Brun	Ruskea	Hnědá	Barna	Brązowa	Καφέ	Коричневый
DL	Mørkeblå	Mørkeblå	Tummansininen	Tmavomodrá	Sötétkék	Granatowa	Σκούρο μπλε	Тёмно-синий
DG	Mørkegrønn	Mørkegrøn	Tummanvihreä	Tmavozelená	Sötétzöld	Ciemnozielona	Σκούρο πράσινο	Тёмно-зелёный
G	Grønn	Grøn	Vihreä	Zelená	Zöld	Zielona	Πράσινο	Зелёный
GY	Grå	Grå	Harmaa	Šedá	Szürke	Szara	Γκρι	Серый
LB	Lyseblå	Ljusblå	Vaaleansininen	Bleděmodrá	Világoskék	Jasnoniebieska	Ανοικτό μπλε	Голубой
LG	Lysegrønn	Ljusgrøn	Vaaleanvihreä	Světlezelená	Világoszöld	Jasnozielona	Ανοικτό πράσινο	Светло-зелёный
N	Naturfarger	Naturfärger	Luonnonväri	Přírodní barva	Természetes színű	Barwy naturalne	Φυσικά χροκαλί	Телесный
O	Orange	Orange	Oranssi	Oranžová	Narancs	Pomarańczowa	Πορφυρό	Оранжевый
P	Rosa	Rosa	Rosa	Růžová	Rózsaszín	Różowa	Ροζ	Розовый
R	Rød	Röd	Punainen	Červená	Piros	Czerwona	Κόκκινο	Красный
PU	Purpur	Pur Pur	PurPurra	Purpurová	Bíborvörös	Purpurowa	Πορφυρό	Пурпурный
SB	Himmelblå	Himmelsblå	Taivaansininen	Blankytná	Égszínkék	Błękitna	Γαλάζιο	Небесно-голубой
T	Gulbrun	Gulbrun	Keltaisenruskea	Žlutohnědá	Sárgásbarna	Żółto-brązowa	Κίτρινοκαφέ	Жёлто-коричневый
W	Hvid	Vit	Valkionen	Bílá	Fehér	Biała	Λευκό	Белый
Y	Gul	Gul	Keltainen	Žlutá	Sárga	Żółta	Κίτρινο	Жёлтый
V	Violet	Violett	Violet	Fialová	Ibolyakék	Fioletowa	Μοβν	ФиФиолетовый



- (GB)** Movement Arrow
- (D)** Bewegungspfeil
- (E)** Flecha de movimiento
- (F)** Flèche indiquant sens du mouvement
- (I)** Freccia di movimentov
- (P)** Flexa de movimento
- (NL)** Richtingspijl
- (DK)** Bevægelsespil
- (N)** Bevegelsespil
- (S)** Rörelsepil
- (SF)** Liikesuuntanuoli
- (CZ)** Šipka pohybu
- (H)** Mozgásirányjelző nyíl
- (PL)** Strzałka kierunku ruchu
- (GR)** Βέλος κίνησης
- (RUS)** Стрелка по направлению

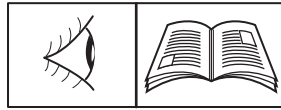

- (GB)** See Workshop Manual
- (D)** Siehe Werkstatthandbuch
- (E)** Ver manual de taller
- (F)** Voir Manuel d'atelier
- (I)** Vedere manuale officina
- (P)** Cf. o manual da oficina
- (NL)** Zie werkplaatshandboek
- (DK)** Se værkstedshåndbog
- (N)** Se verkstedshåndboka
- (S)** Se verkstadshandboken
- (SF)** Katso korjaamon käsikirjasta
- (CZ)** Viz dílenskou příručku
- (H)** Lásd a Műhely-kézikönyvben
- (PL)** Patrz podręcznik warsztatowy
- (GR)** λέπε Εγχειρίδιο Συνεργείου
- (RUS)** Смотри руководство для мастерской



- (GB)** Disconnect
- (D)** Abklemmen
- (E)** Desconectar
- (F)** Déconnecter
- (I)** Staccare
- (P)** Desligar
- (NL)** Demonteren
- (DK)** Frakobles
- (N)** Klem av
- (S)** Koppla los
- (SF)** Irrota
- (CZ)** Odpojit
- (H)** Szakítsa meg, kapcsolja szét
- (PL)** Rozłączyć
- (GR)** Αποσύνδεση
- (RUS)** Разъедините



- (GB)** Connect
- (D)** Verbinden
- (E)** Conectar
- (F)** Connecter
- (I)** Collegare
- (P)** Ligar
- (NL)** In elkaar
- (DK)** Kobles
- (N)** Tilkopling
- (S)** Ansult
- (SF)** Yhdistä
- (CZ)** Spojit
- (H)** Kapcsolja össze
- (PL)** Połączyć
- (GR)** Σύνδεση
- (RUS)** Соедините



- (GB)** Warning
- (D)** Achtung
- (E)** Atención
- (F)** Attention
- (I)** Attenzione
- (P)** Atenção
- (NL)** Let op
- (DK)** Bemærk
- (N)** Pass på
- (S)** Varning
- (SF)** Huomio
- (CZ)** Pozor
- (H)** Figyelem
- (PL)** Uwaga
- (GR)** Προσοχή
- (RUS)** Осторожно



- (GB)** Throw away
- (D)** Entsorgen
- (E)** Tratamiento de residuos
- (F)** Jeter aux déchets
- (I)** Smaltire
- (P)** Eliminar
- (NL)** Weggooien
- (DK)** Affald
- (N)** Avskaffe
- (S)** Ta hand om avfallet
- (SF)** Hävittää
- (CZ)** Vyhodit
- (H)** Távolítsa el
- (PL)** Usunąć jako odpad
- (GR)** Απόσυρση
- (RUS)** Выбросите

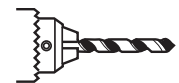

- (GB)** Use Drill
- (D)** Bohrer verwenden
- (E)** Utilizar broca
- (F)** Utiliser une mèche
- (I)** Utilizzare trapano
- (P)** Utilizar a perfuradora
- (NL)** Boordiameter
- (DK)** Bor anvendes
- (N)** Bruk diameter
- (S)** Använd borr
- (SF)** Käytä poraa
- (CZ)** Použít vrták
- (H)** Használjon fúrót
- (PL)** Stosować wiertarkę
- (GR)** Χρησιμοποιείτε τρυπάνι
- (RUS)** Используйте дрель



- (GB) Tape up
- (D) Mit Klebeband befestigen
- (E) Fijar con cinta adhesiva
- (F) Fixer avec ruban adhésif
- (I) Fissare con nastro adesivo
- (P) Sujeitar com fita adesiva
- (NL) Vastzetten met tape
- (DK) Fastgøres med tape
- (N) Fest fast med klebebånd
- (S) Fästet med tejp
- (SF) Kiinnytys teipillä
- (CZ) Upevnit lepicí páskou
- (H) Rögzítse ragasztószalaggal
- (PL) Umocować taśmą samoprzylepną
- (GR) Στερέωση με κολλητική ταινία
- (RUS) Прикрепите клейкой лентой



- (GB) Use Scissors
- (D) Schere verwenden
- (E) Utilizar tijeras
- (F) Utiliser des ciseaux
- (I) Utilizzare forbice
- (P) Utilizar serra
- (NL) Gebruik Schaar
- (DK) Saks anvendes
- (N) Bruk saks
- (S) Använd sax
- (SF) Käytä saksia
- (CZ) Použít nůžky
- (H) Használjon ollót
- (PL) Stosować nożyce
- (GR) Χρησιμοποιείτε αλίδ
- (RUS) Использовать ножницы



- (GB) Location/Position Arrow
- (D) Positionspfeil
- (E) Flecha de posición
- (F) Flèche de Position
- (I) Freccia di posizione
- (P) Flexa de posição
- (NL) Lokatie/Positie pijl
- (DK) Lokaliseringspil
- (N) Posisjonspil
- (S) Positionpil
- (SF) Paikannusnuoli
- (CZ) Šipka na pozici
- (H) Helyzetjelző nyíl
- (PL) Strzałka położenia
- (GR) Βέλος θέσης
- (RUS) Позиция



- (GB) Degrease
- (D) Entfetten
- (E) Desengrasar
- (F) Dégraisser
- (I) Sgrassare
- (P) Desengordurar
- (NL) Ontvetten
- (DK) Fjerne fedt
- (N) To bort fettet
- (S) Avfettning
- (SF) Rasvanpoisto
- (CZ) Odmastit
- (H) Zsírtalanítás
- (PL) Odtłuścić
- (GR) Απολίπανση
- (RUS) Обезжирьте

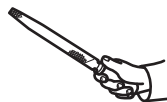

- (GB) Use File
- (D) Feile verwenden
- (E) Utilizar lima
- (F) Utiliser lime
- (I) Utilizzare lima
- (P) Utilizar lima
- (NL) Vijl
- (DK) Fil anvendes
- (N) Bruk fil
- (S) Använd fil
- (SF) Käytä viilaa
- (CZ) Použít pilník
- (H) Használjon reszelőt
- (PL) Stosować pilnik
- (GR) Χρησιμοποιείτε λίμα
- (RUS) Использовать напильник

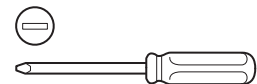

- (GB) Use Flat End Screwdriver
- (D) Schraubenzieher verwenden
- (E) Utilizar destornillador
- (F) Utiliser tournevis
- (I) Utilizzare cacciavite
- (P) Utilizar chave de fendas
- (NL) Zaaggleufschroevendraaier
- (DK) Skruetrækker anvendes
- (N) Bruk skrujern
- (S) Använd skruvmejsel för raka spår
- (SF) Käytä ruuvitalttaa
- (CZ) Použít šroubovák
- (H) Használjon csavarhúvót
- (PL) Stosować śrubokręt
- (GR) Χρησιμοποιείτε κατασβίδ
- (RUS) Используйте крестовую отвёртку

A

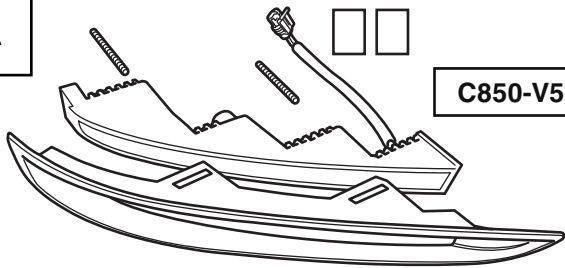

L C853-V5-750

R C854-V5-750

2x

B

L C853-V5-750

R C854-V5-750

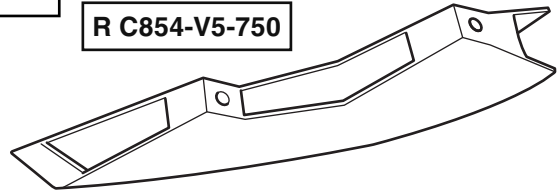

2x

E

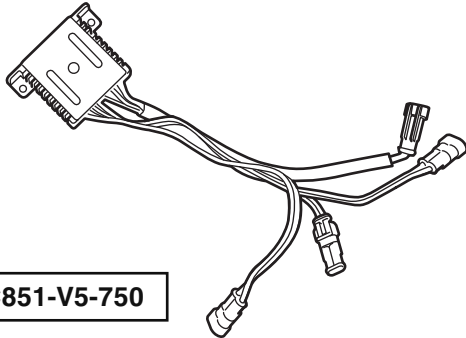

1x

F

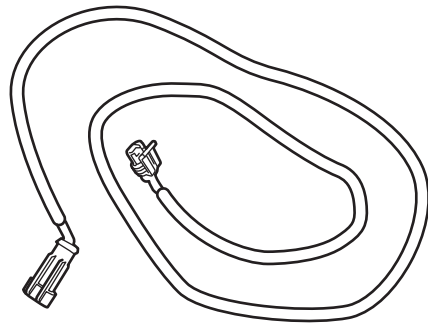

1x

G



1x

H

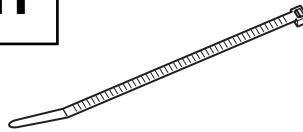

5x

I

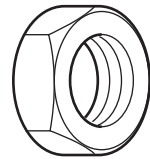

4x

J

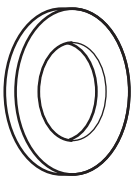

4x

K

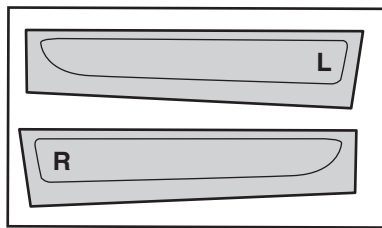

1x

L



1x

M

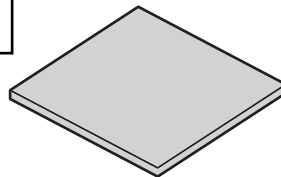

1x

N

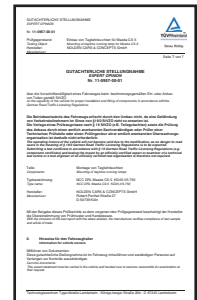

1x

C

KD53-V5-751

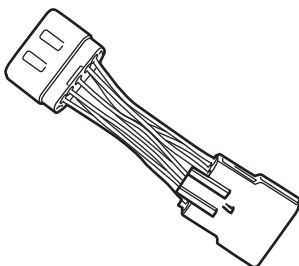

1x

D

KD45-V5-751

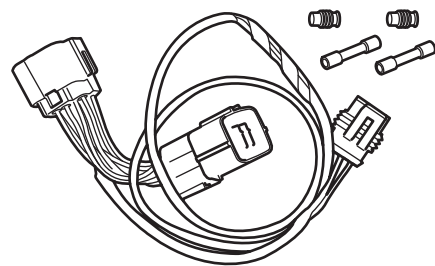

1x

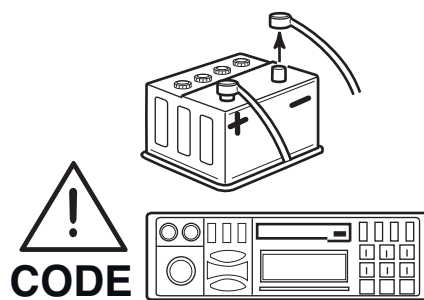

1

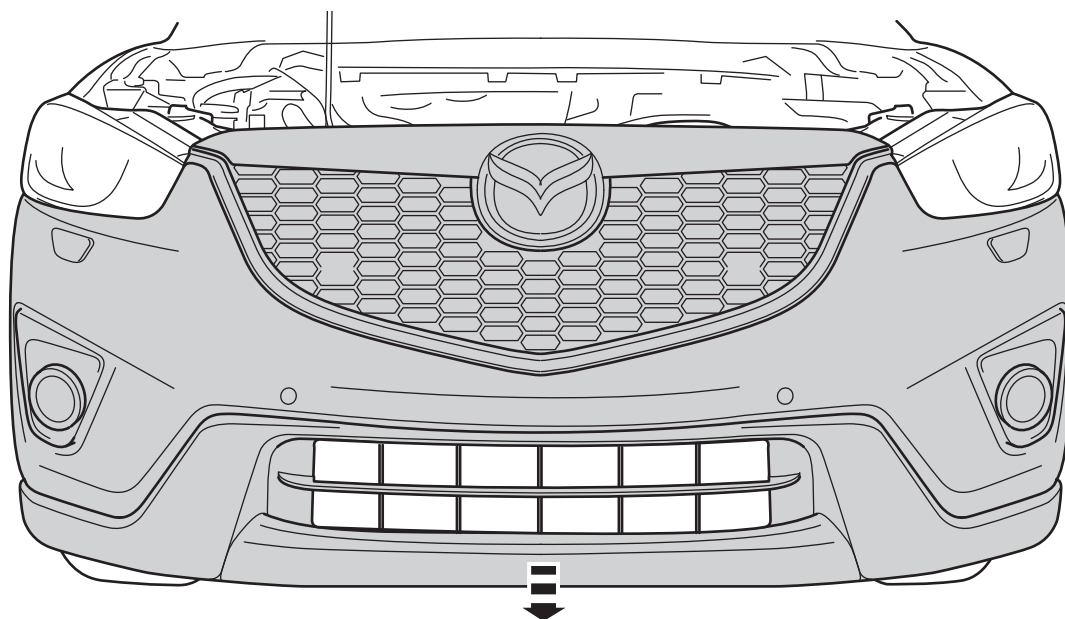

2

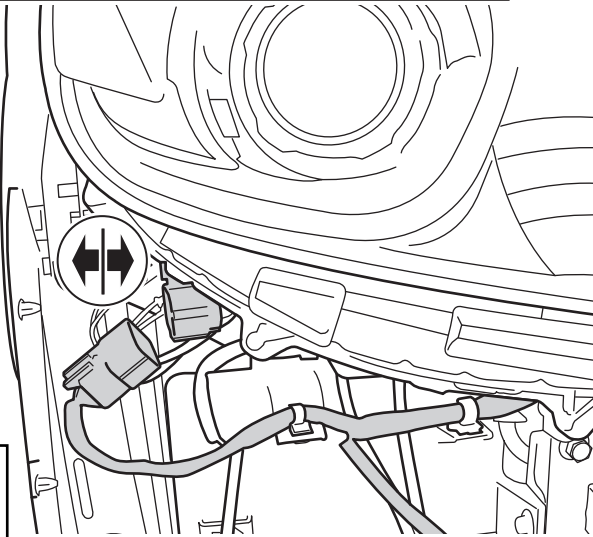
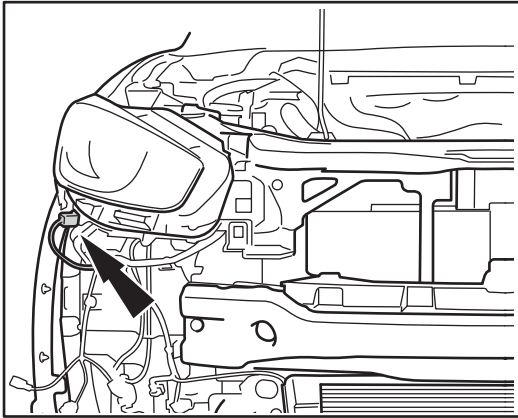

3

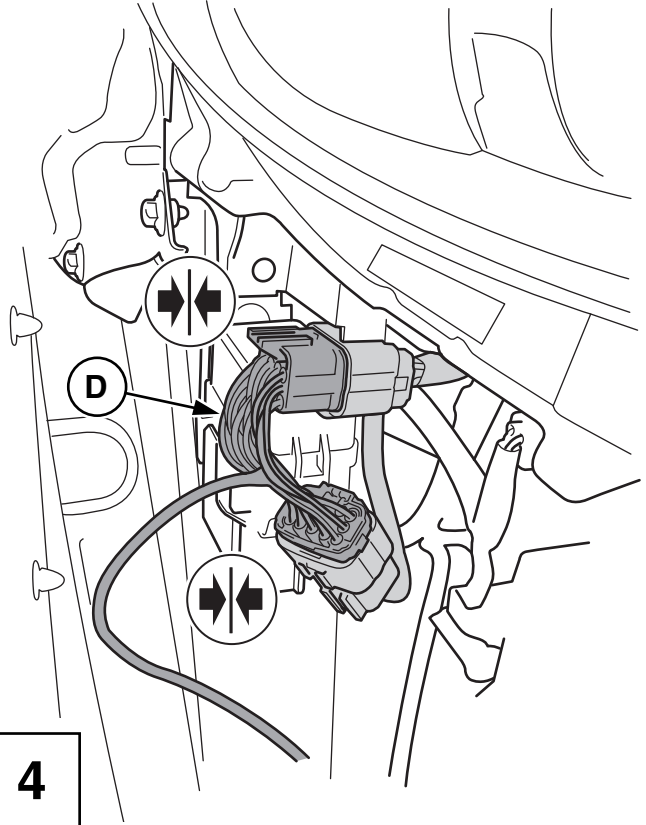

4

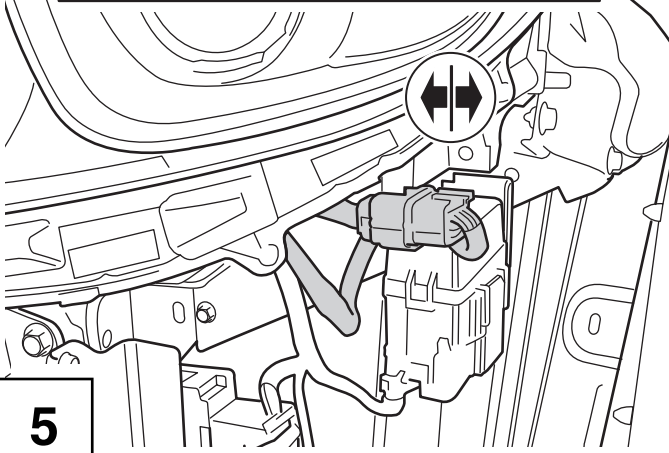
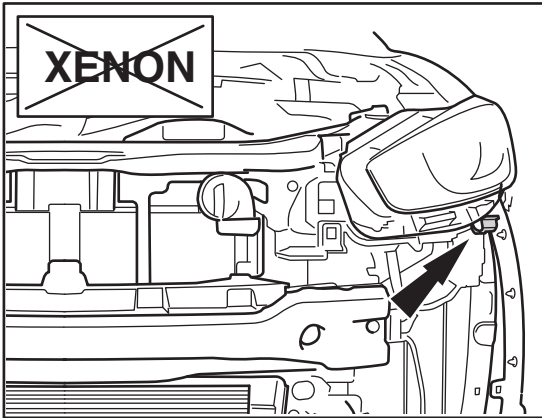

5



6

XENON

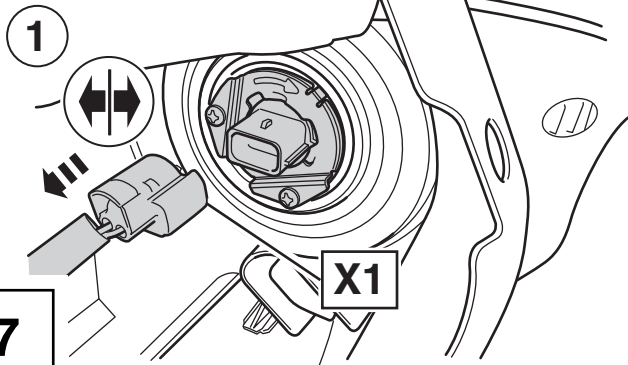
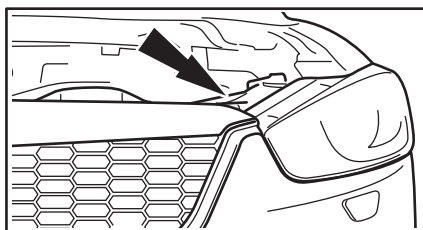

7

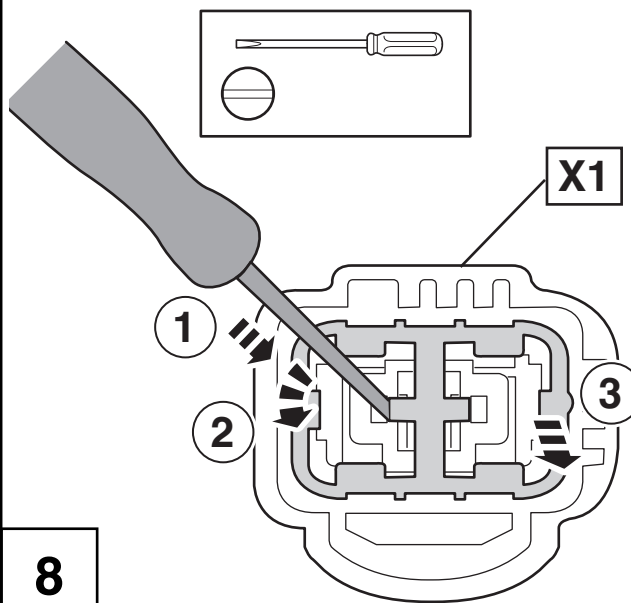

8

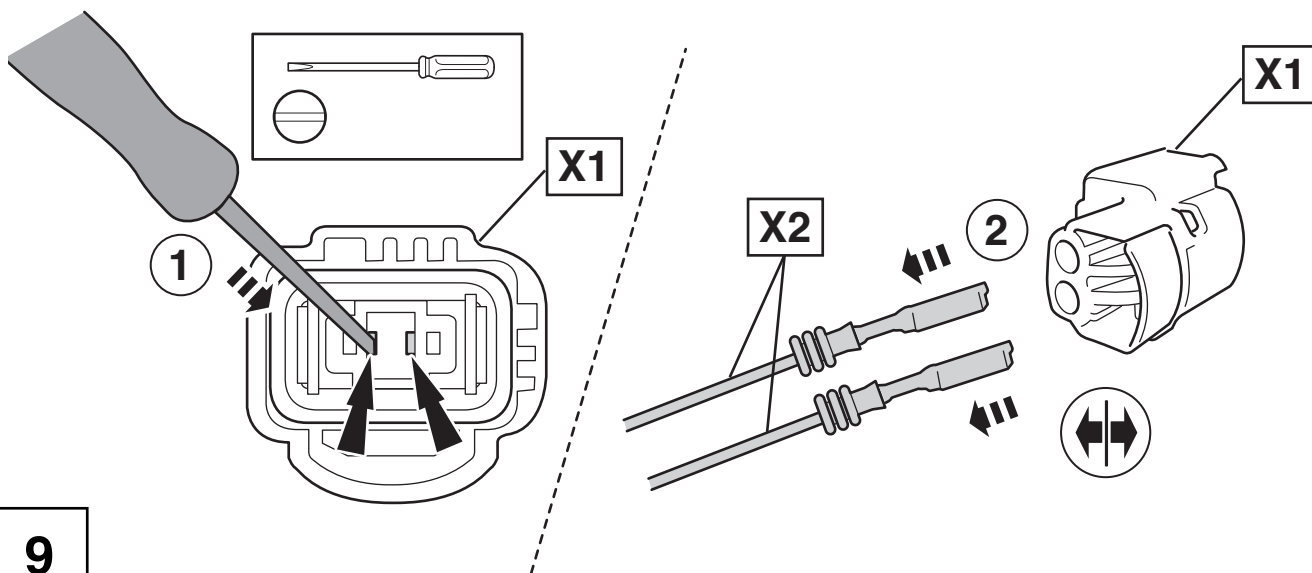

9

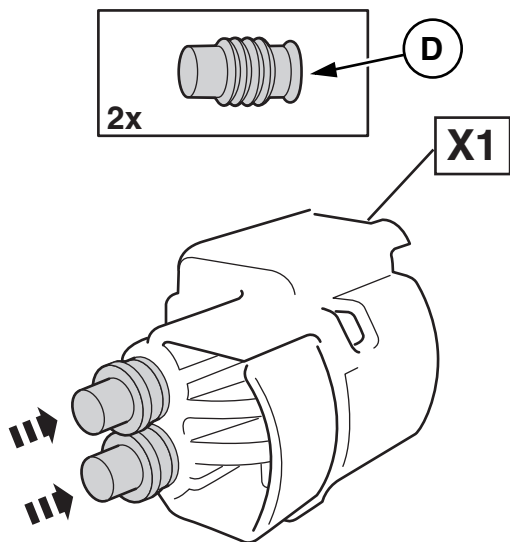

10

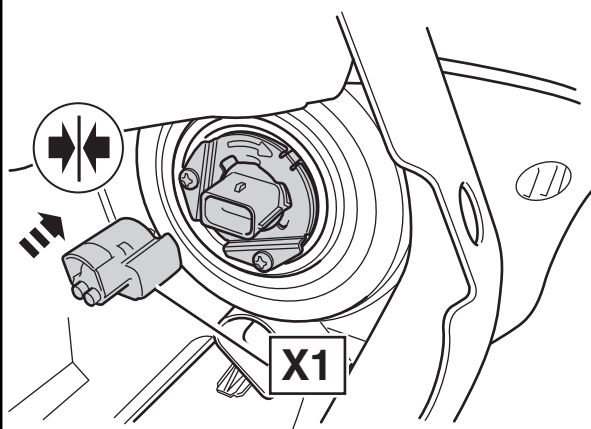

11

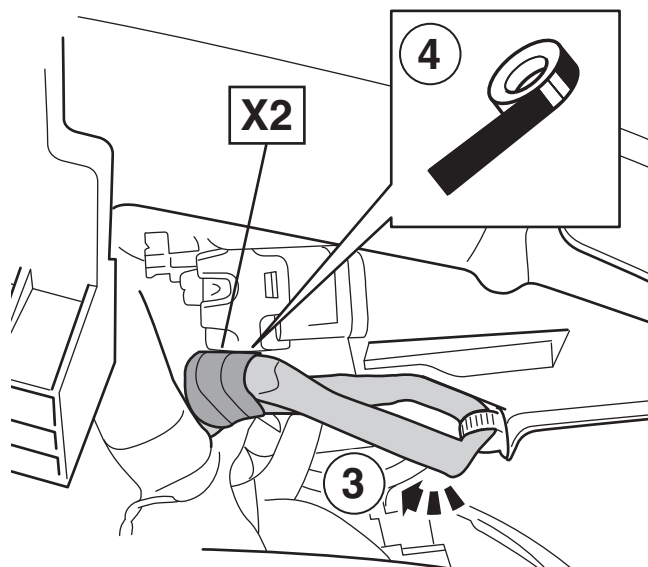
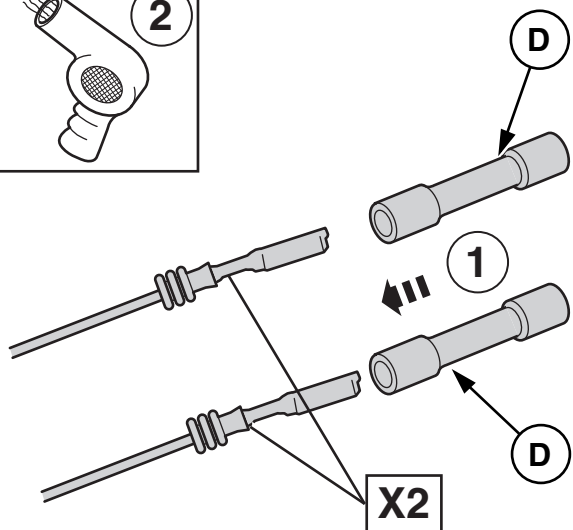
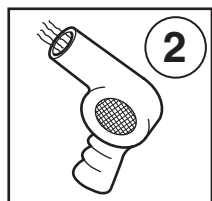

12

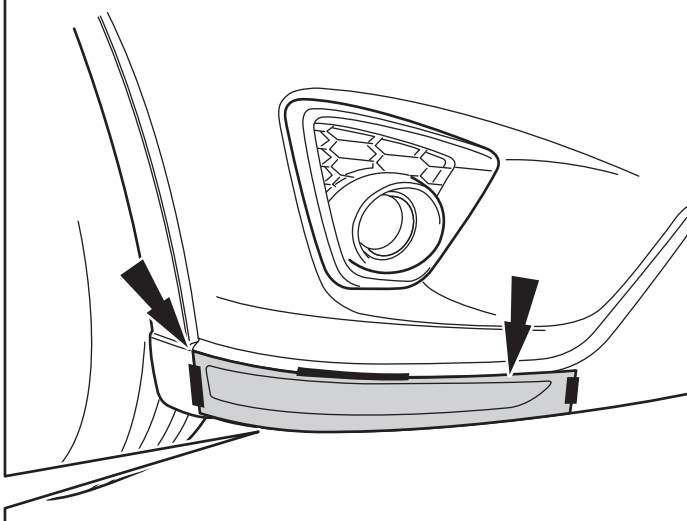
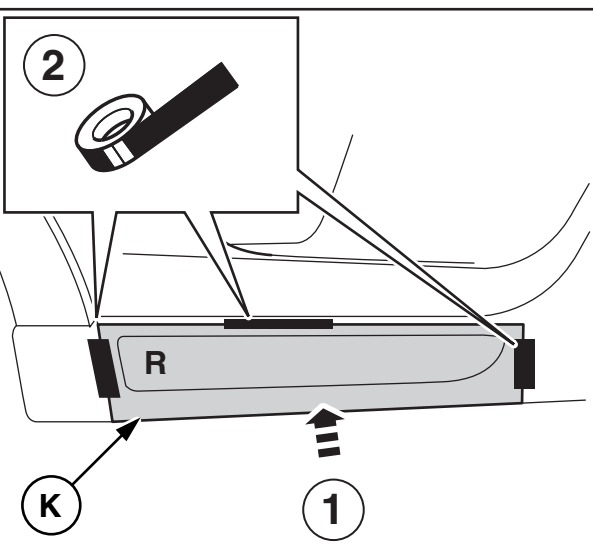

13

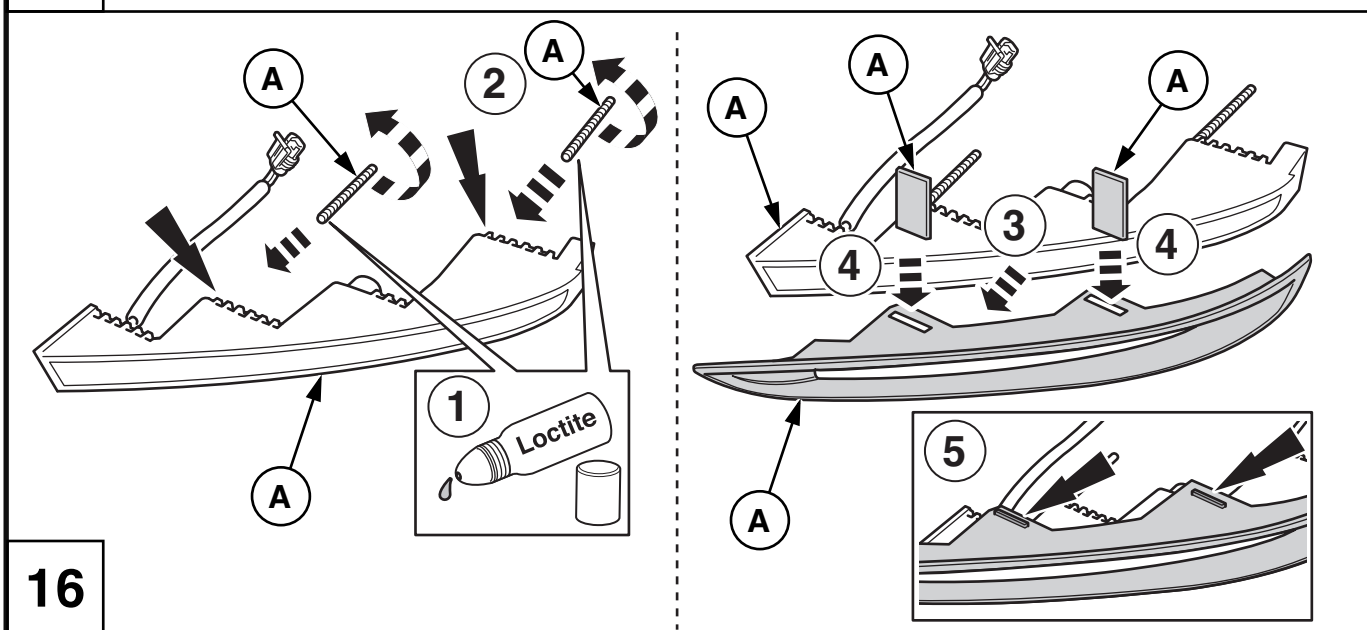
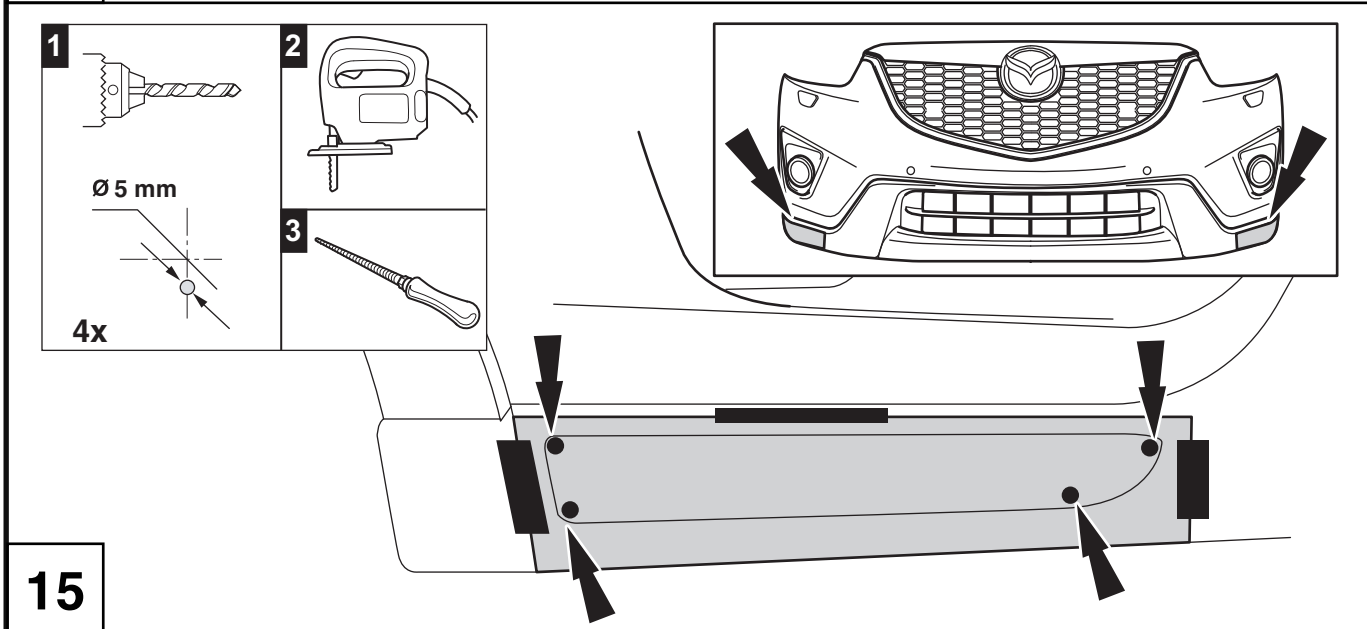
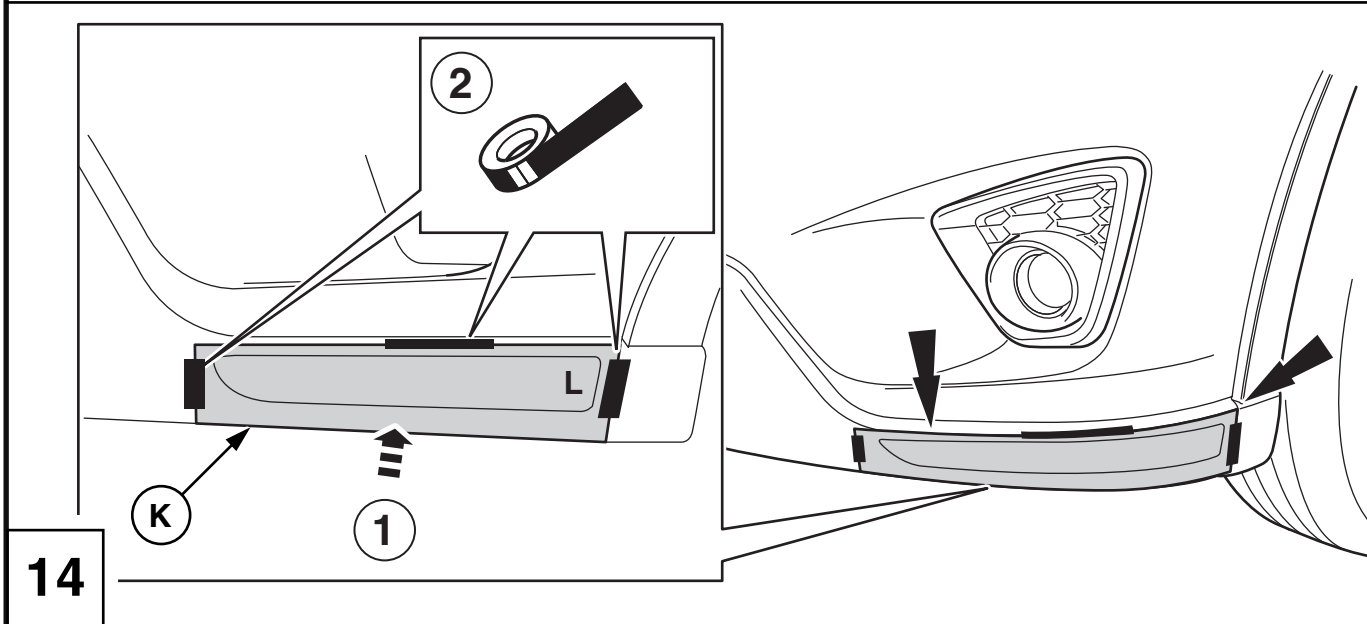

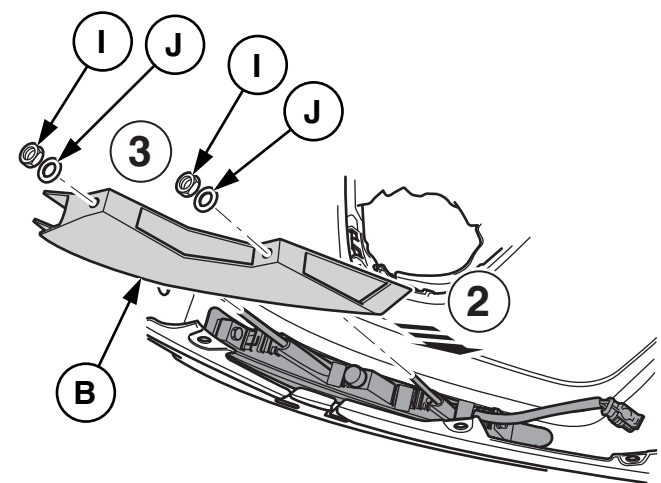
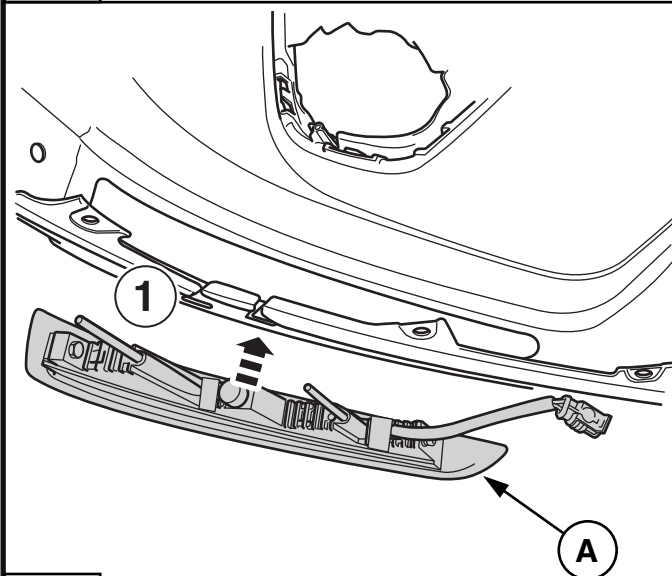
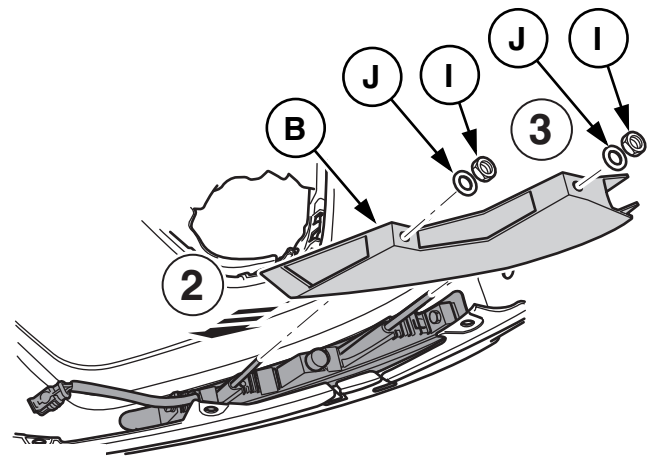
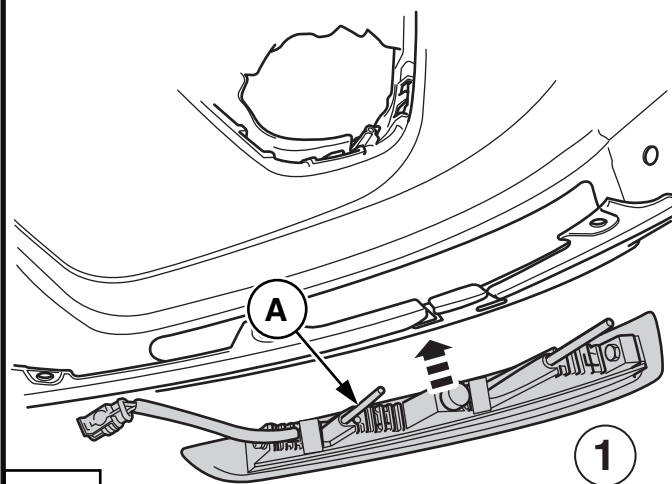
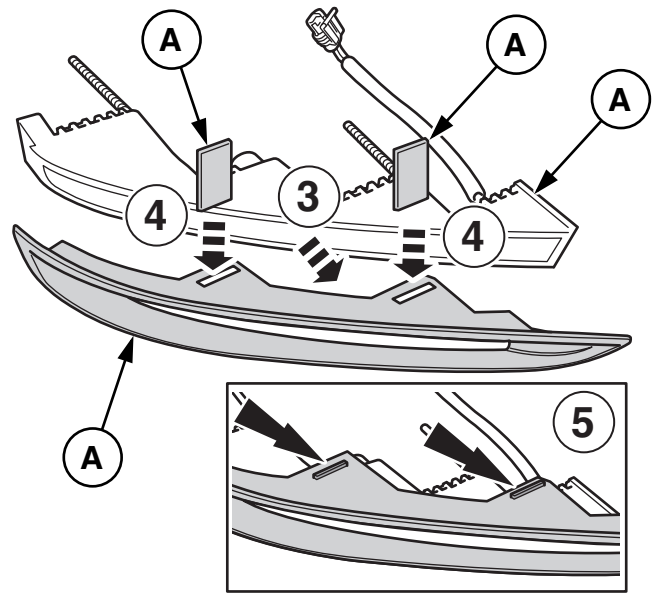
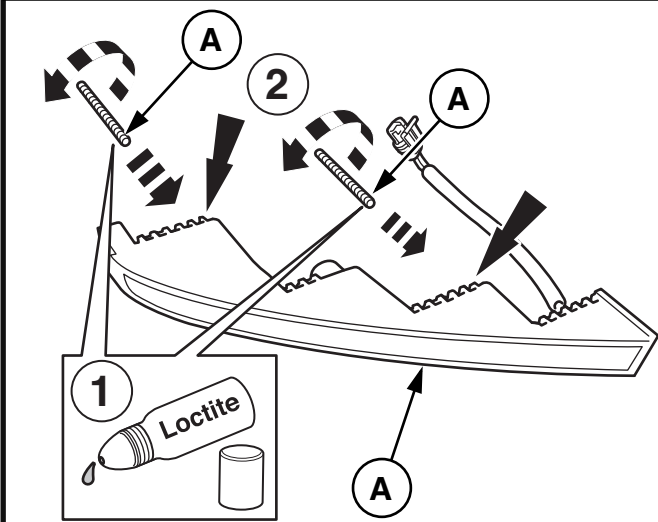

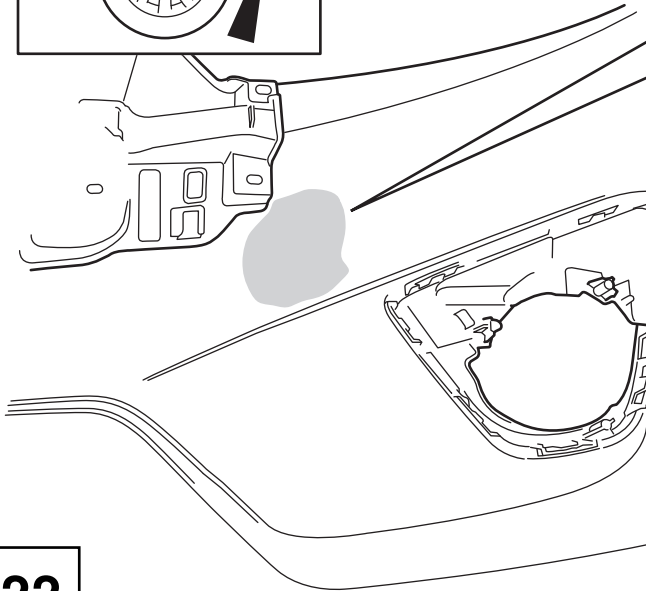
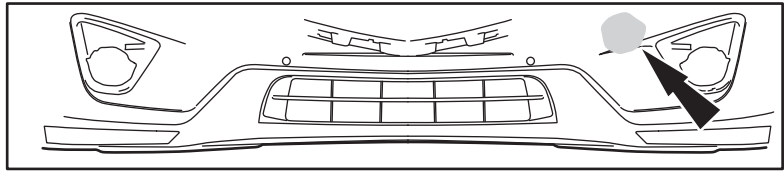
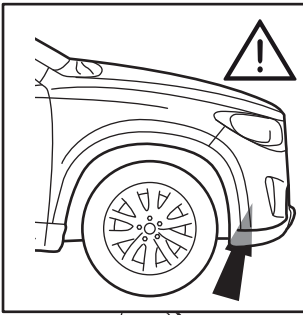

1 CLEANER

2

3

5 min

(L)

22

E

1 CLEANER

2

3

5 min

(L)

23

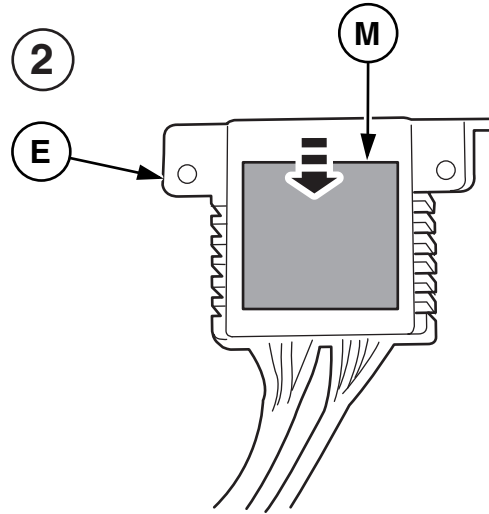
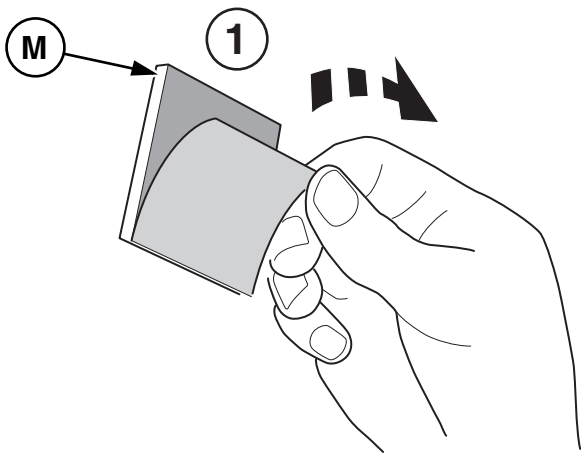

24

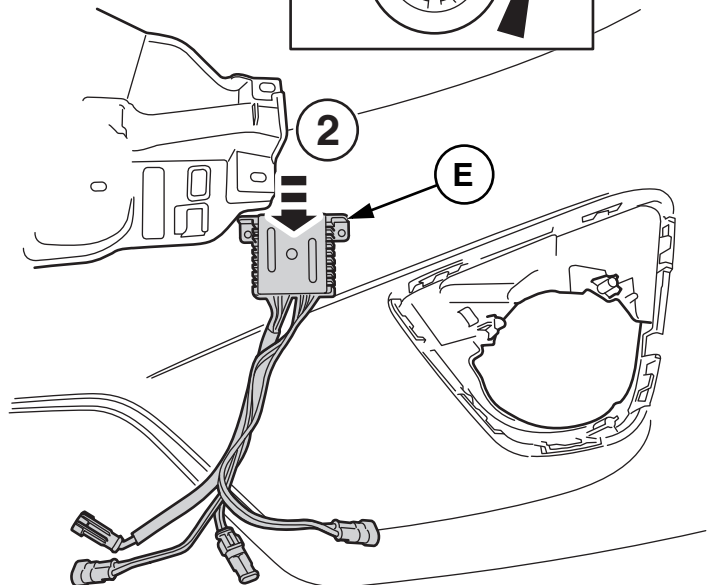
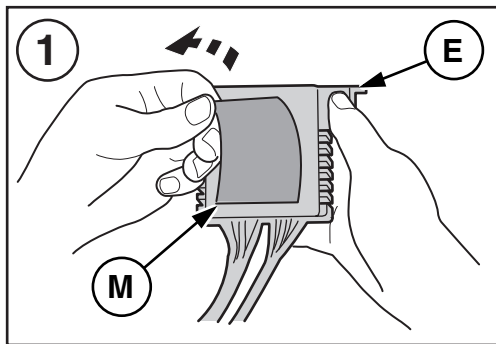
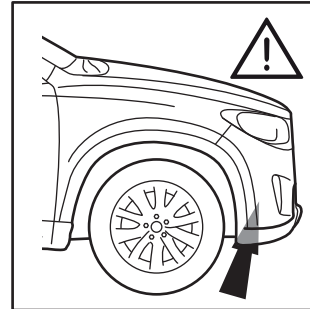
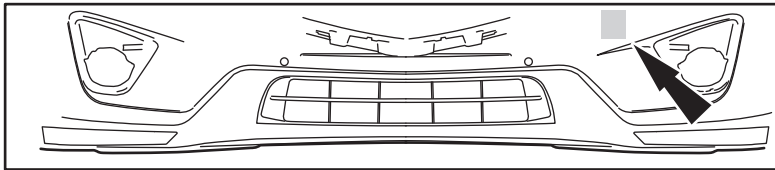

25

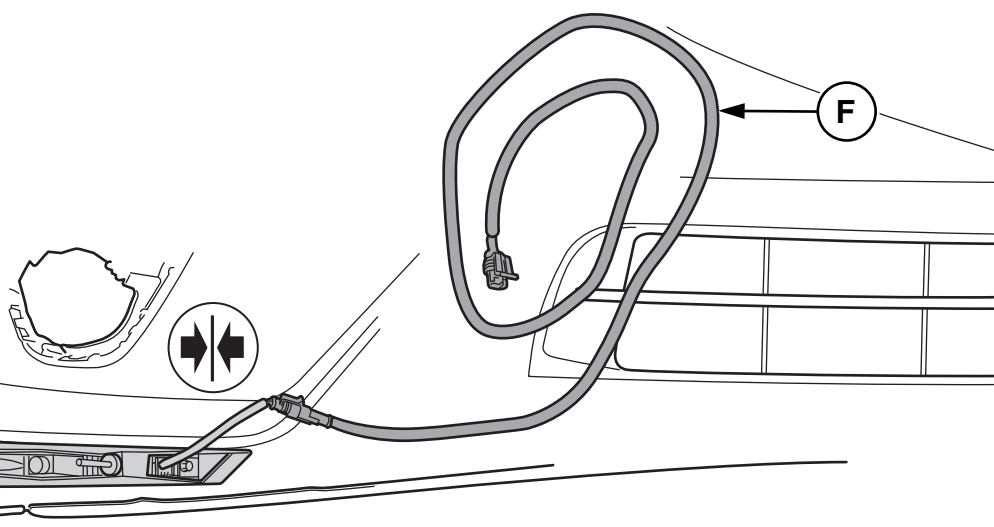
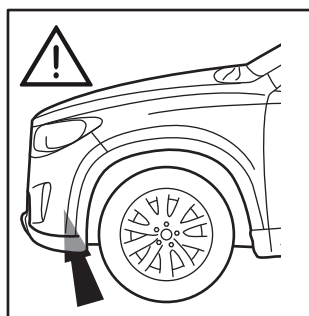

26

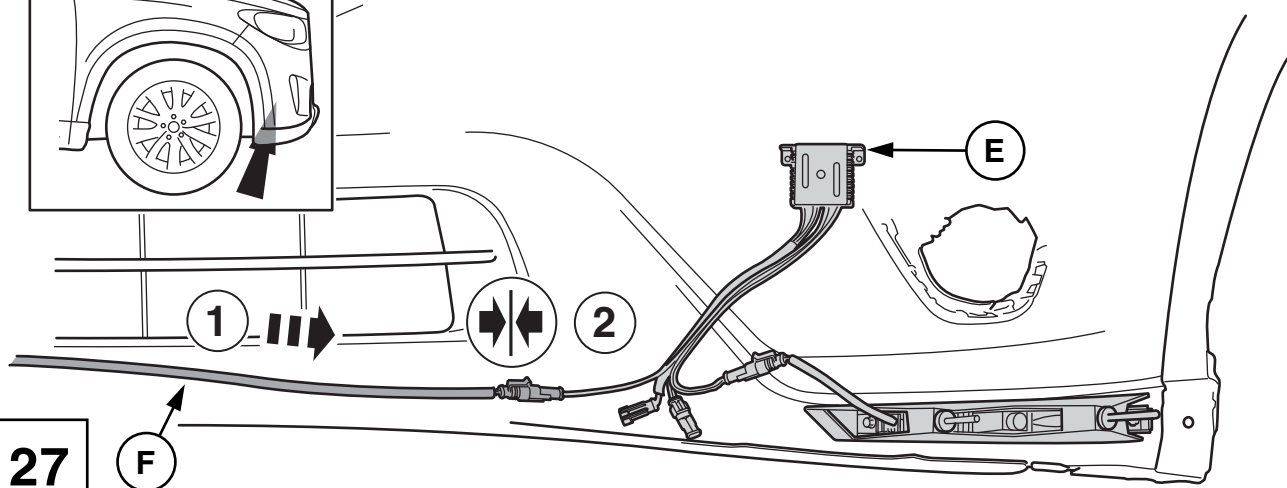
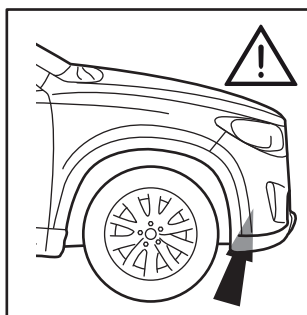

27

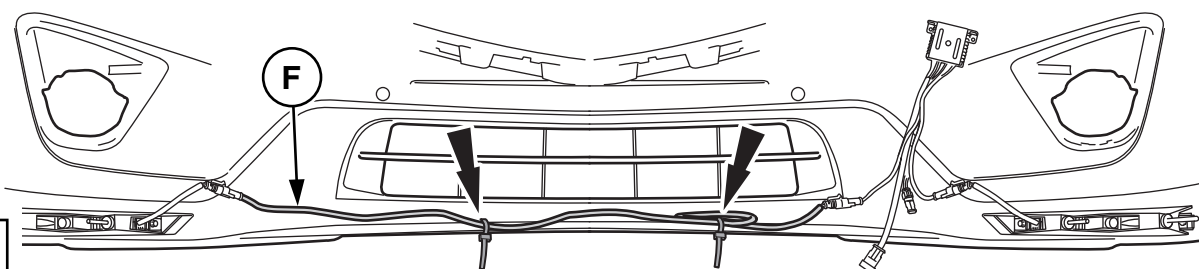
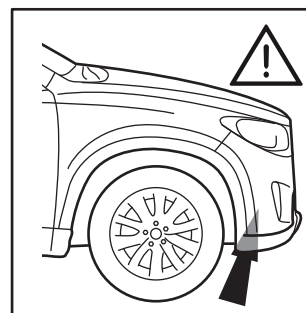
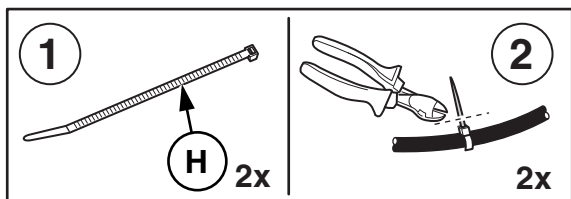

28

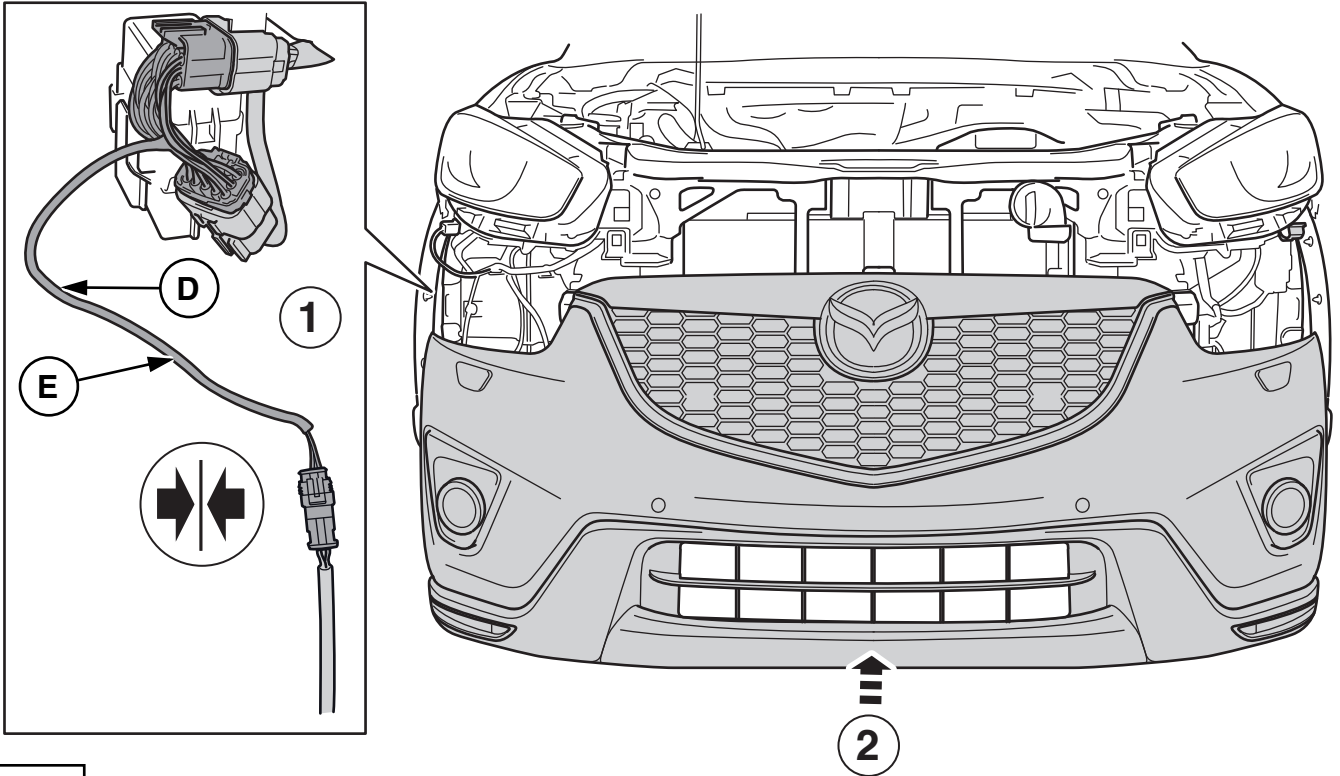

29

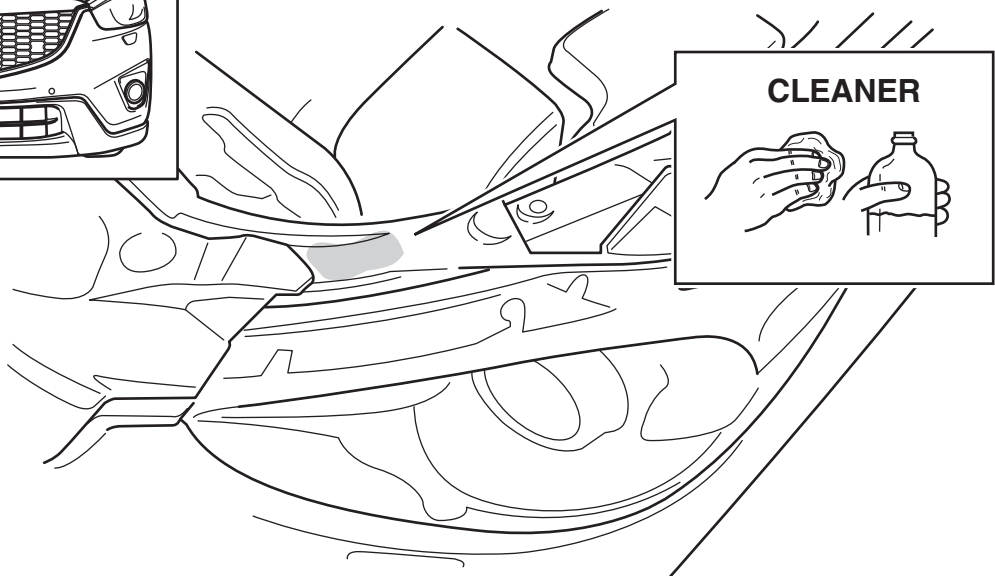
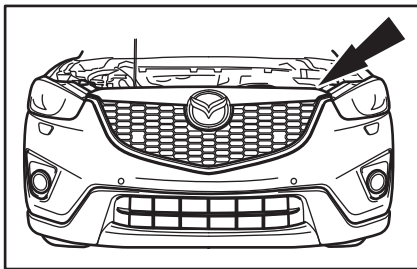

30

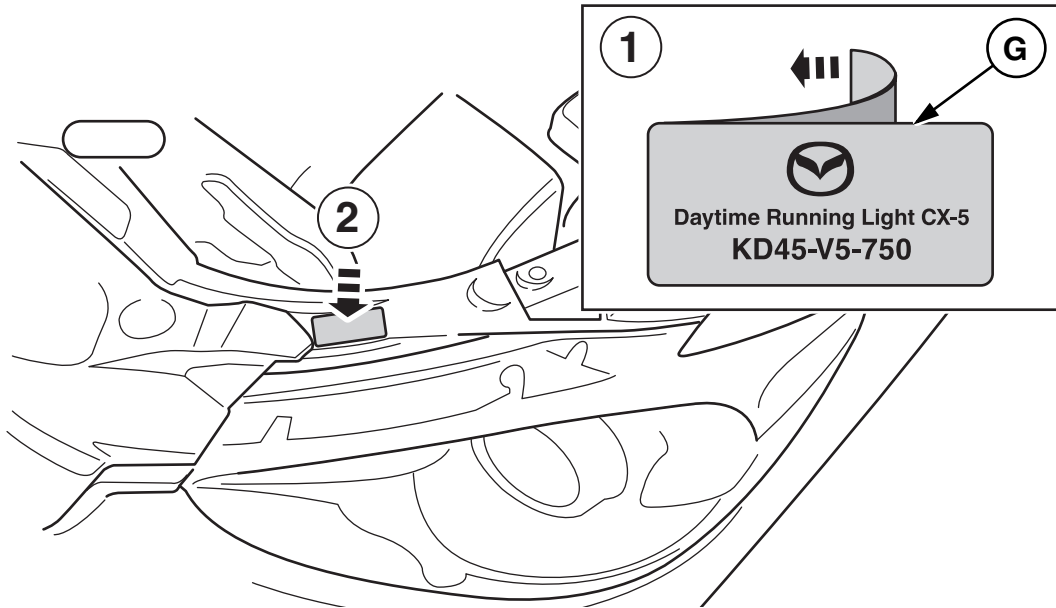

31

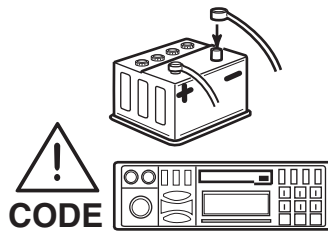

32

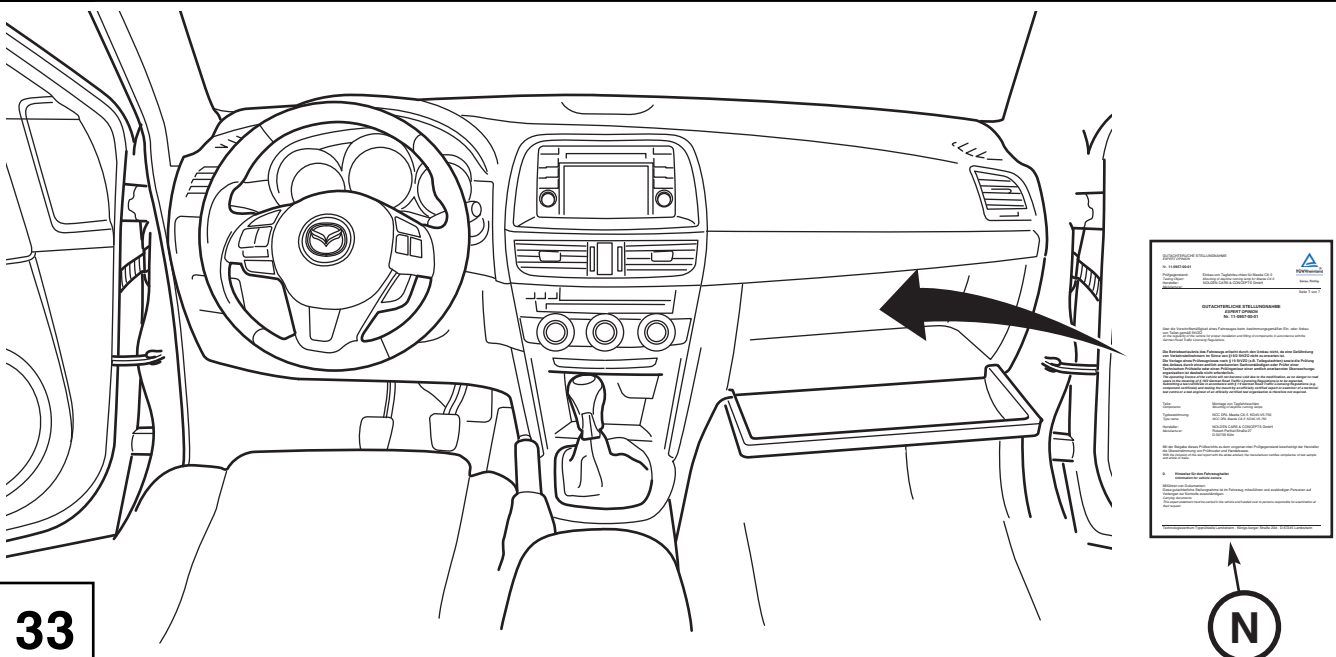

33