

# GENUINE SCUFF PLATES

## Using (Installation) Instructions

Applicable model : MAZDA 2

Part number : DF71 V1 370F

Thank you very much for buying the Mazda Genuine Parts.

Before removal and installation, you are expected to carefully read these instructions.

To use it in its best conditions, be sure to read thoroughly read these instructions for full understanding of the contents and to properly use it.

### < Cautions and Requests >

⚠ Caution and ⚠ Warning marks shown in these instructions indicate safety precautions, which you are requested to strictly comply with during installation and use.

⚠ **WARNING** : Indicates a situation in which serious injury or death could result if the warning is ignored.

⚠ **CAUTION** : Indicates a situation in which bodily injury or damage to the vehicle could result if the caution is ignored.

Always avoid any installation and use that are not stated in these instructions.

Do not ever alter the product when installing the product.

To ensure safety and reliability of the work, installation, removal and disposal work must be carried out by an Authorized Mazda Dealership.

If you have any questions about the use of the product, ask your Mazda dealer for proper advice before using it.

Mazda and its suppliers are not responsible for injuries, accidents, and damage to persons and property that arise from the failure of the dealer or installer to follow these instructions.

Be careful not to lose removed parts, and be sure that they are kept free from scratches, grease or other dirt.

#### **To the dealer**

Please turn over these instructions to the customer after installation.

#### **To the customer**

Keep these instructions after installation. The instructions may be necessary for installing other optional parts or removal of this accessory.

Should the vehicle or this accessory be resold, always leave these instructions with it for the next owner.

**Mazda Motor Corporation**

3-1, Shinch, Fuchu-cho, Aki-gun Hiroshima

1

# AS-COMPLETED VIEW (The illustrations show LH side)

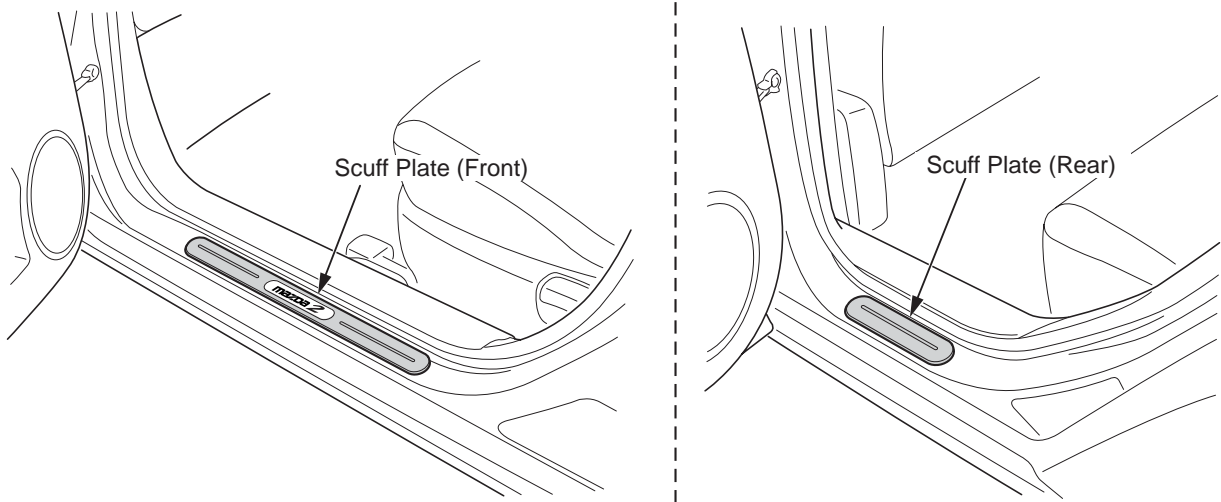

2

## COMPONENTS

### ⚠ CAUTION

Make sure that there is no missing component based on the following parts list and check the components for any dirt, scratches or other damage.

No.	Part name	Q'ty
	Scuff plate (front)	2
	Scuff plate (rear)	2
	Template	1
	Using (installation) instructions	1

①



②

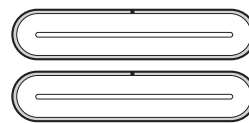

③

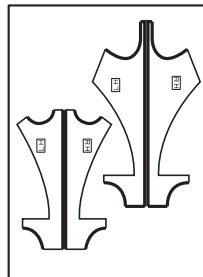

④



### 3

## PREPARATORY WORK BEFORE INSTALLATION

**Tools used** (Have them ready at hand before starting the work.)

- ◆ Degreasing agent or mild detergent such as isopropyl alcohol or white gasoline
- ◆ Dryer or infrared ray lamp (cold season)
- ◆ Waste cloth
- ◆ Protective sheet
- ◆ Masking tape
- ◆ Scissors
- ◆ Wheel block

### ! WARNING

- Make sure that operation is carried out on the level ground with the parking brake pedal and chock block securely set. Otherwise, vehicle may start to move and injury may result.

### ! CAUTION

Place the removed parts and components on a protective sheet or equivalent to avoid any damage on such parts/components.

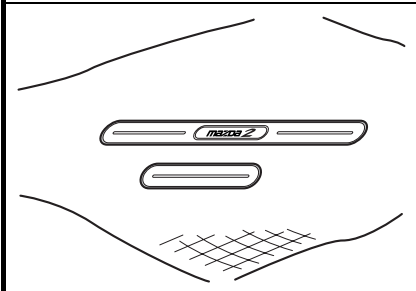

### Two-sided tape applying procedure

※The adherend indicates door or bumper, and the parts indicates the accessories.

#### 1. Avoid the ambient temperature below 15°C

The adhesiveness of adhesive tape depends on the softness of plastic. So at a lower temperature (5°C or lower), the stickiness of the tape decreases and the adhesive power decreases.

Therefore installation work should always be carried out at temperatures of 15 degrees C or higher.

Otherwise, the adherend and parts should be warmed enough before starting work.

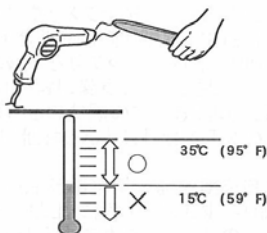

#### 2. Uniform pressure bonding

It is necessary to press the bonding plane to the adherend evenly with uniform pressure in order to get enough space to apply two-sided tape. Especially press the end of the tape well and when the adherend is curved.

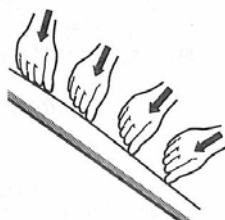

#### 3. Wash the adherend

If there's dust, dirt or grease on the surface of adherend, the surface of two-sided tape will splotch and adhesive power of the tape will be reduced. It is required to wash the surface of the adherend before adhesion. Be sure to use mild detergent for interior parts, IPA (isopropyl alcohol) or white gasoline for exterior parts.



#### 4. Keep the tape from dirt

Be careful not to touch the adhesive surface. Otherwise, the grease on your hand clings to the surface of the tape and adhesive power will be reduced. Also, when wearing gloves, be careful not to soil the adhesive surface with the lint and grease from the gloves. Be sure to keep the adhesive surface of the tape from any dirt.



#### 5. Handling after installation

To ensure high adhesion strength, avoid driving the car or washing the installed products (and around the products) within 24 hours after installation. And never remove and then re-adhere the tape after having applied the product to the installation surface since it will significantly reduce the tape's adhesive power.

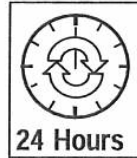

## 4 INSTALLING THE SCUFF PLATE (FRONT)

(Directions are given for the left side. The right side is symmetric.)

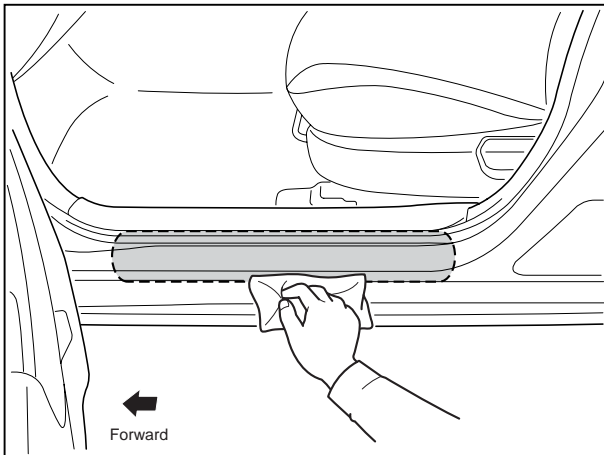

1. Open the front door and clean the scuff plate (front) mounting surface using a cloth soaked in white gasoline or neutral detergent. Then dry it completely.

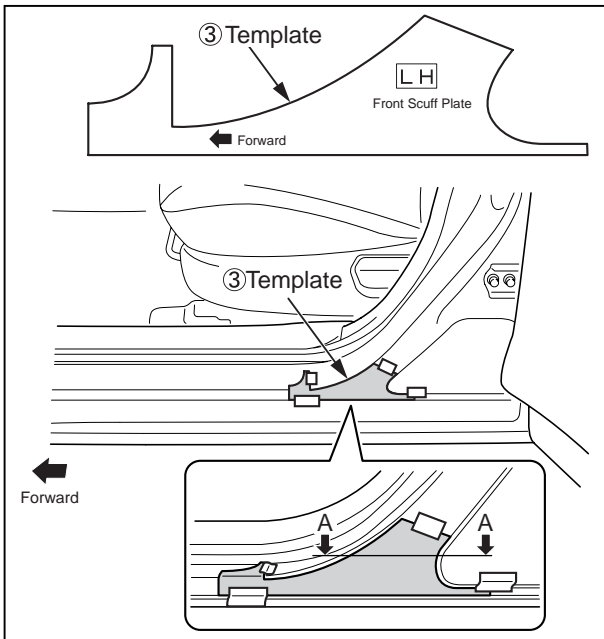

2. Cut out the template with using scissors.
3. Align the template to the outline of the vehicle shape and fix it with using masking tape.

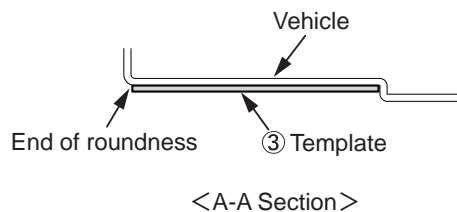

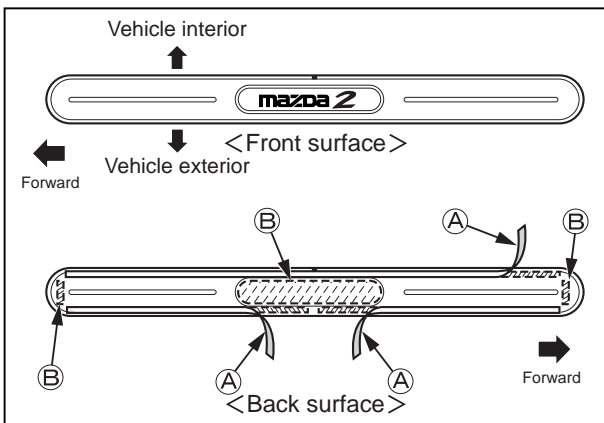

4. Remove the separators of two-sided tape on the back surface of the scuff plate (front) as shown in the left diagram.

- (A): Remove about 3 to 5 cm (3 places)
- (B): Remove completely (3 places)

**CAUTION**

- When temperatures are low (15 or under), use a dryer or equivalent to warm up the two-sided tape and installation surface before proceeding. However, be sure not to heat the product at high temperatures (50 or higher). Otherwise, products may get deformed.

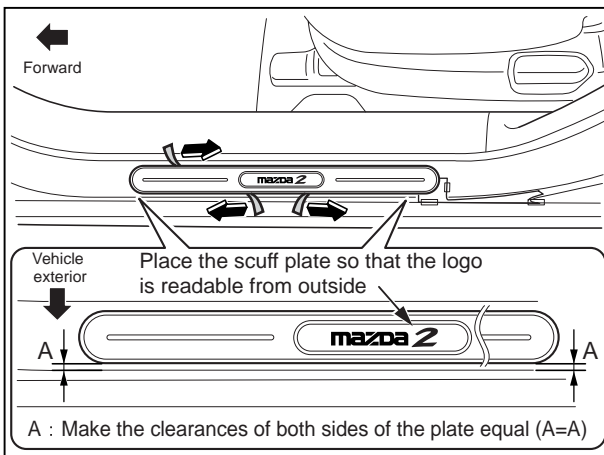

5. Align the scuff plate (front) to the "Scuff plate alignment line" of the template and temporarily position it on the vehicle.

6. After aligning it, remove all the half-removed separators carefully and press the scuff plate (front) well.

**CAUTION**

- Do not push too hard when pressing the two-sided tape. Otherwise, the scuff plate (front) may get deformed. Be careful not to damage or deform the scuff plate.

7. Remove the templates.

## 5 INSTALLING THE SCUFF PLATE (REAR)

(Directions are given for the left side. The right side is symmetric.)

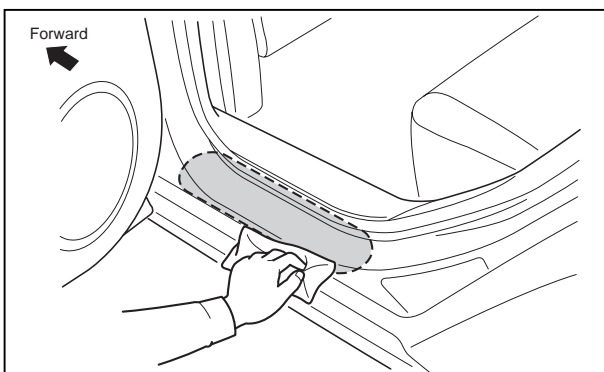

1. Open the rear door and clean the scuff plate (rear) mounting surface using a cloth soaked in white gasoline or neutral detergent. Then dry it completely.

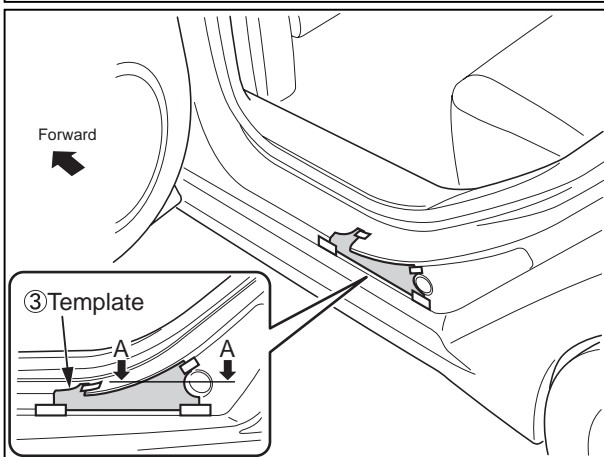

2. Cut out the template with using scissors.

3. Align the template to the outline of the vehicle shape and fix it with using masking tape.

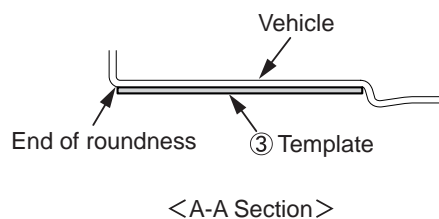

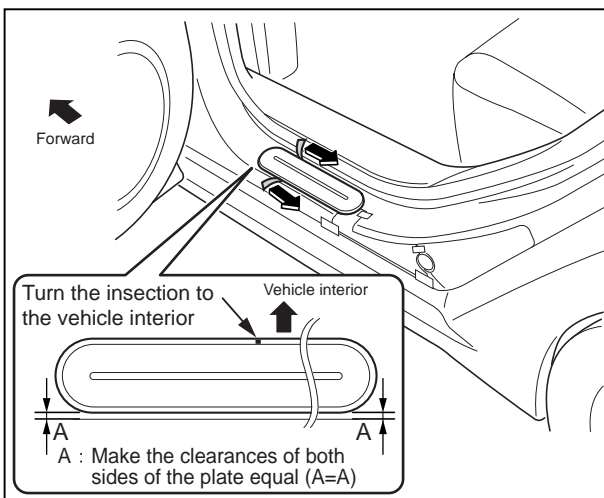
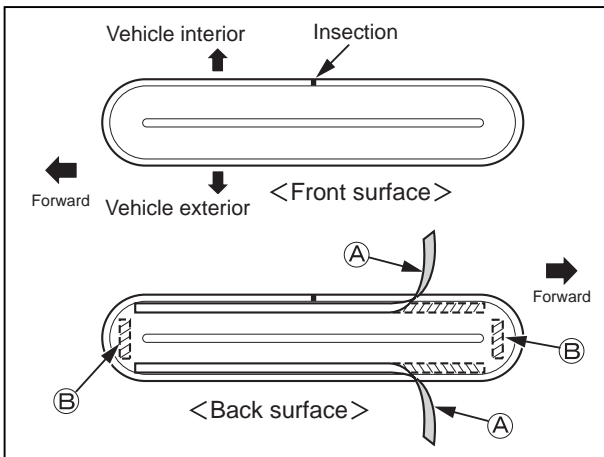

4. Remove the separators of two-sided tape on the back surface of the scuff plate (rear) as shown in the left diagram.

- (A) : Remove about 3 to 5 cm (2 places)
- (B) : Remove completely (3 places)

**CAUTION**

- When temperatures are low (15 or under), use a dryer or equivalent to warm up the two-sided tape and installation surface before proceeding. However, be sure not to heat the product at high temperatures (50 or higher). Otherwise, products may get deformed.

5. Align the scuff plate (rear) to the “Scuff plate alignment line” of the template and temporarily position it on the vehicle.

6. After aligning it, remove all the half-removed separators carefully and press the scuff plate (rear) well.

**CAUTION**

- Do not push too hard when pressing the two-sided tape. Otherwise, the scuff plate (rear) may get deformed. Be careful not to damage or deform the scuff plate (rear).

7. Remove the templates.

## 6 CAUTIONS AND WARNINGS WHEN HANDLING

**WARNING**

- Keep the products away from a live cigarette and volatile (thinner, alcohol) and flammable objects. Fire or deformation may occur.

**CAUTION**

- In the event of dirt, use a soft cloth soaked in a diluted neutral detergent and wipe the dirt away. Do not use thinner, alcohol or other such solvents.
- When using chemical textile, be sure to follow the instructions of the textile.
- Prevent the product from a sharp-pointed and hard objects like an umbrella or a stick. Otherwise, scratches or breakage may occur.
- If an alcohol-containing fluid (Ex: thinner, wax, benzine, insecticide etc) or juice was spilled on the products, immediately wipe off the spilt liquid. Otherwise, discoloration or corrosion of the plate may occur.
- This product is designed for ornamental purpose. Do not ever put your foot on the scuff plate.

### To the customer

- If you have any questions about the use of the product, ask your Mazda dealer for proper advice.

# Installation Inspection Sheet

【 To be used by installation workshop 】

MAZDA 2	SCUFF PLATES
	DF71 V1 370F

## Inspection items after installation

- After installing the vehicle parts, check for dirt. Clean any dirty parts.
- Inspect the installed parts and removed and re-installed parts following the items below.

Section to be inspected	Inspection item (circle)			
	Gap / fit & finish	Scratch, stain	Tightening & engagement	Tape residue
Scuff plate				
Front door				
Rear door				
Around the scuff plates mounting areas				

## Scuff plates installation inspection

Date		(year/month/day):			
VIN No.					
Approved		Checked		Prepared	

Retention period of the sheet : 12 months

# TEMPLATE

## SCUFF PLATES

- Applicable model : MAZDA 2
- Part number : DF71 V1 370F

