

MAZDA

GB PARKING BRAKE LEVER COVER Installation instruction	N HÅNDBREMSESTANG Monteringsvejledning
D HANDBREMS HEBEL Einbauanleitung	S HANDBROMSSPAK Monteringsanvisning
E PALANCA DEL FRENO DE MANO Instrucciones de montaje	SF KÄSIJARRUKAHVA Asennusohje
F LEVIER DE FREIN À MAIN Notice de montage	CZ RUČNÍ BRZDA Návod k montáži
I LEVA DEL FRENO A MANO Istruzioni di montaggio	H KÉZIFÉK Beszerelési utasítás
P ALAVANCA DO TRAVÃO DE MÃO Instruções de montagem	PL HAMULEC RECZNY Instrukcja zabudowy
NL GREEP HANDREM Inbouw-instructie	GR χειρόφρενο Οδηγίες τοποθέτησης
DK HÅNDBREMSEGREB Monteringsvejledning	

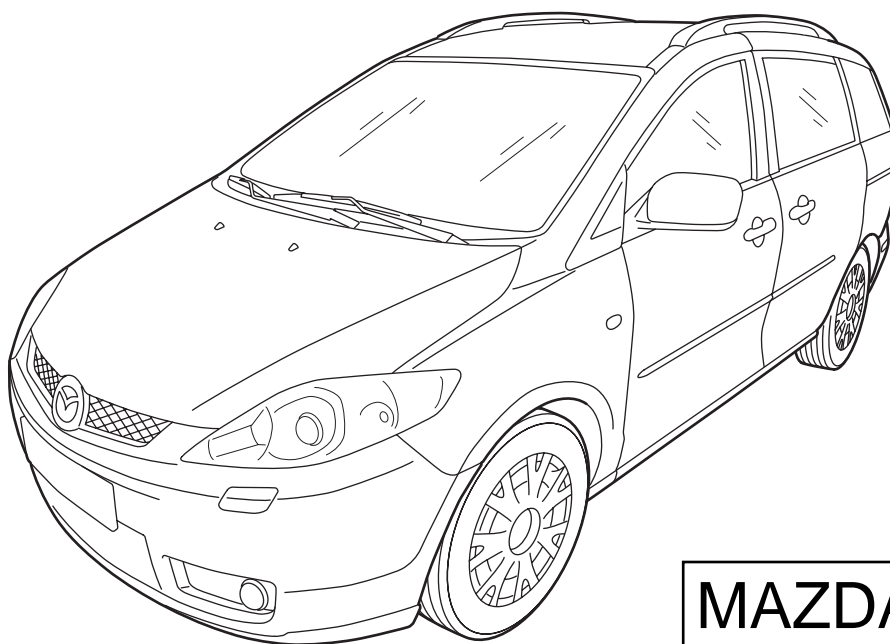

MAZDA 5 CR1

Part No: CC29 V8 190 02
CC29 V8 190 33

Date: 08-04-2005

© Copyrights MAZDA

Sheet 1 of 5

Expert Fitment Required
Montage durch Fachwerkstatt erforderlich
Montaje sólo por el concesionario
Montage par spécialiste nécessaire
E' necessario in officina specializzata
Especialista em montagem requerido
Montage door vakman nodig
Montage ved professionelt værksted påkrævet
Nødvendig med montering fra fagverksted
Verkstadsmontage erfordras
Asennus tarpeen merkkikorjaamossa
Montáž ve specializované dílně nutná
A szereléshez szakműhely kell
Konieczny montaż przez warsztat specjalistyczny
Να τοποθετεί από συνεργείο



- (GB) Location
- (D) Positionspfeil
- (E) Flecha de posición
- (F) Flèche indiquant location
- (I) Freccia di posizione
- (P) Flexa de posição
- (NL) Lokatie
- (DK) Lokaliseringspil
- (N) Posisjonspil
- (S) Positionpil
- (SF) Paikannusnuoli
- (CZ) Šipka na pozici
- (H) Helyzetjelző nyíl
- (PL) Strzałka położenia
- (GR) Βέλος θέσης



- (GB) Movement Arrow
- (D) Bewegungspfeil
- (E) Flecha de movimiento
- (F) Flèche de mouvement
- (I) Freccia di movimento
- (P) Flexa de movimento
- (NL) Richtingspijl
- (DK) Bevægelsespil
- (N) Bevegelsespil
- (S) Rörelsepil
- (SF) Liikesuuntanuoli
- (CZ) Šipka pohybu
- (H) Mozgásirányjelző nyíl
- (PL) Strzałka kierunku ruchu
- (GR) Βέλος κίνησης



- (GB) Throw away
- (D) Entsorgen
- (E) Tratamiento de residuos
- (F) Rebuter
- (I) Smaltire
- (P) Eliminar
- (NL) Weggooien
- (DK) Affald
- (N) Avskaffe
- (S) Ta hand om avfallet
- (SF) Hävittää
- (CZ) Vyhodit
- (H) Távolítsa el
- (PL) Usunąć jako odpad
- (GR) Απόσυρση

A

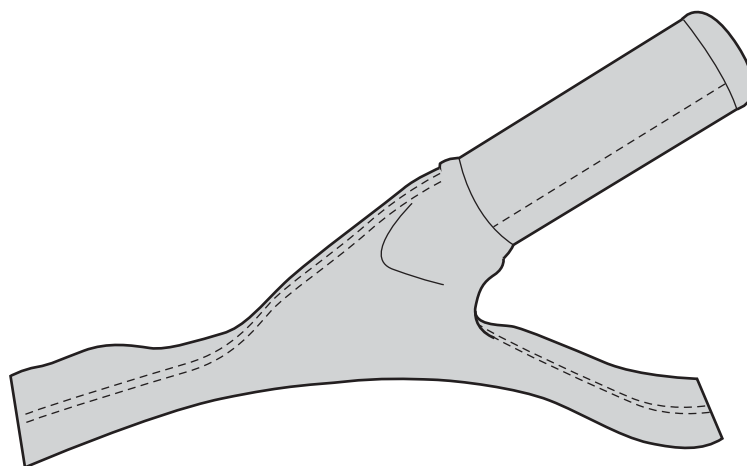

1x

B



M4 x 6 mm

3x

C



1x

D

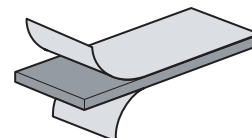

2x

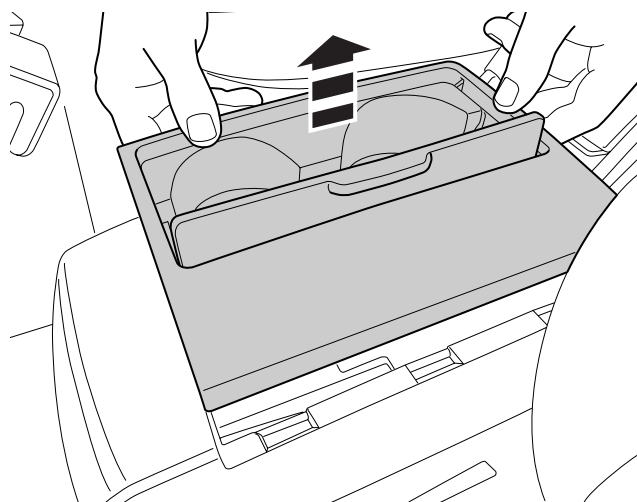

1

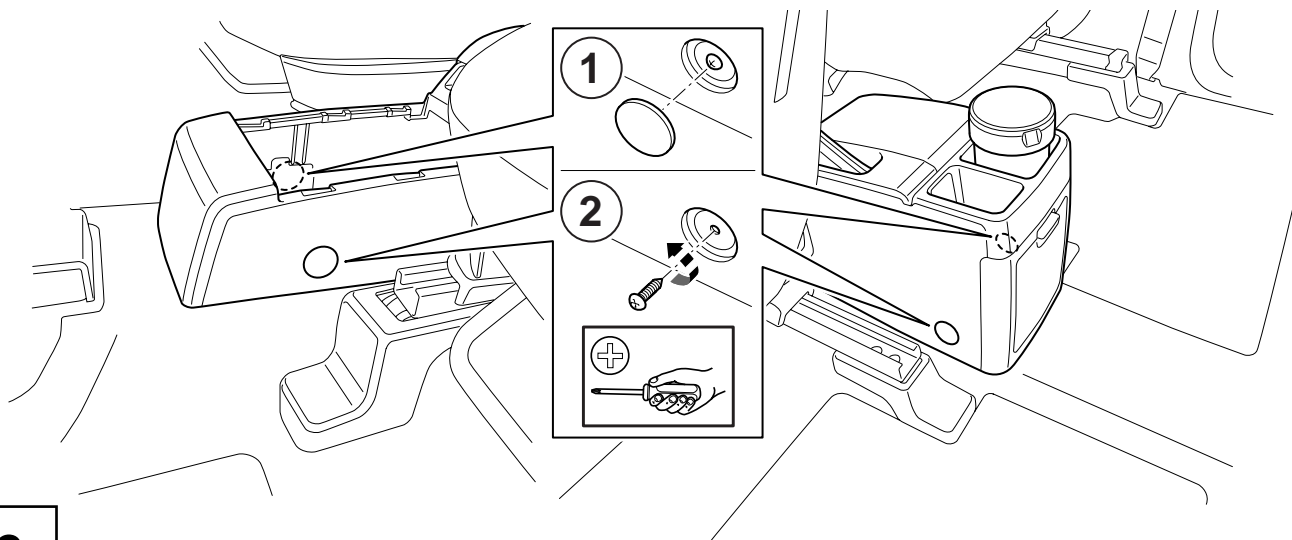

2

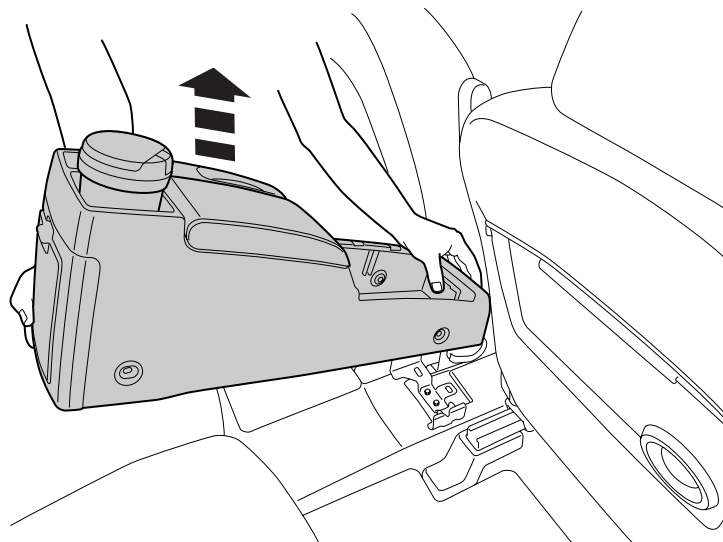

3

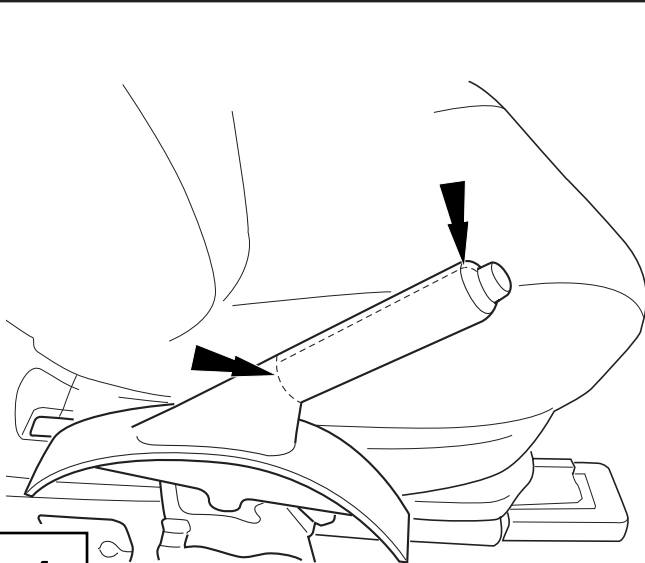

4

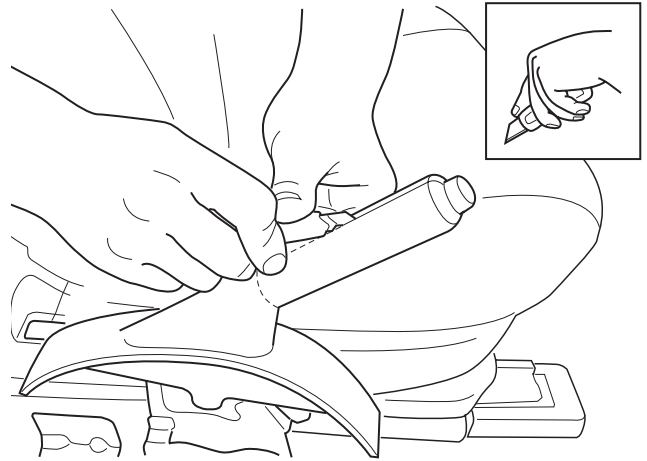

5

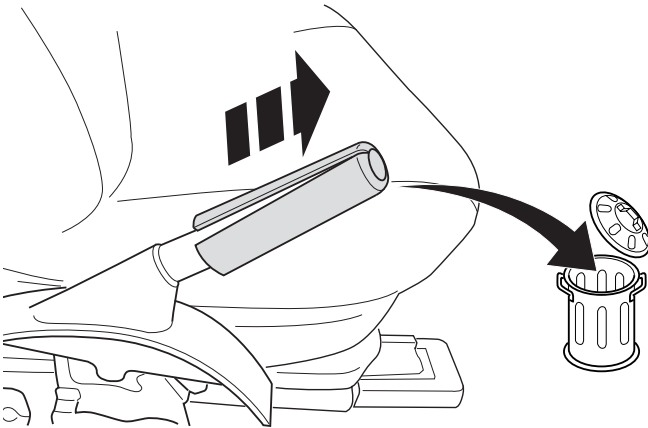

6

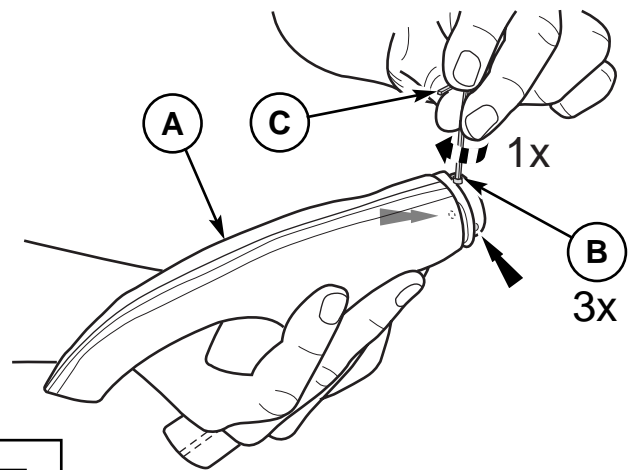

7

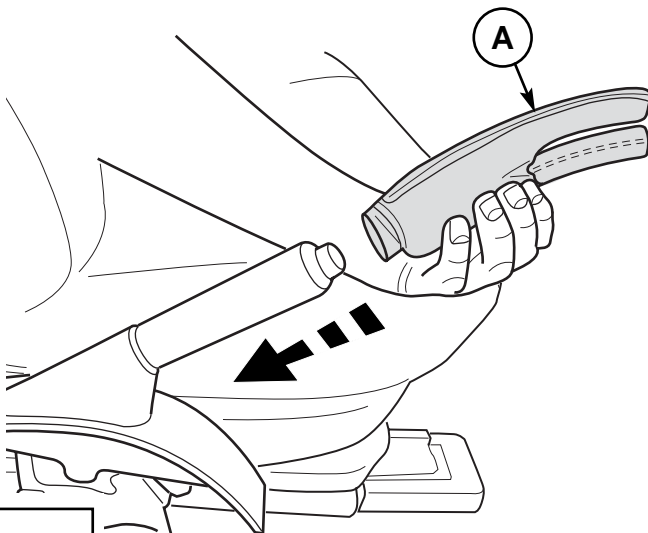

8

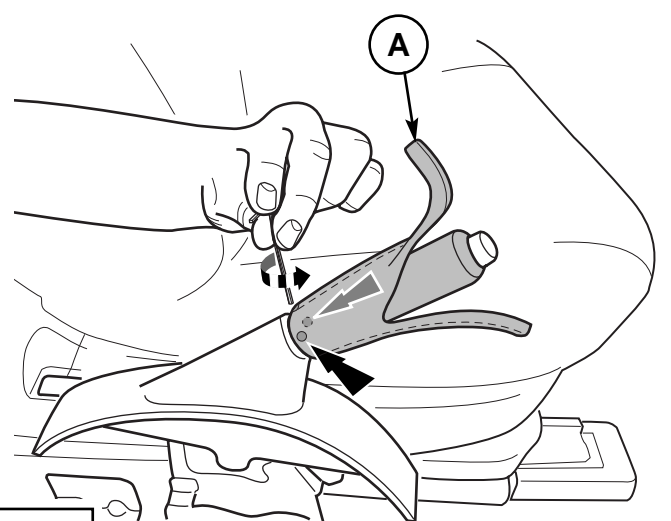

9

10

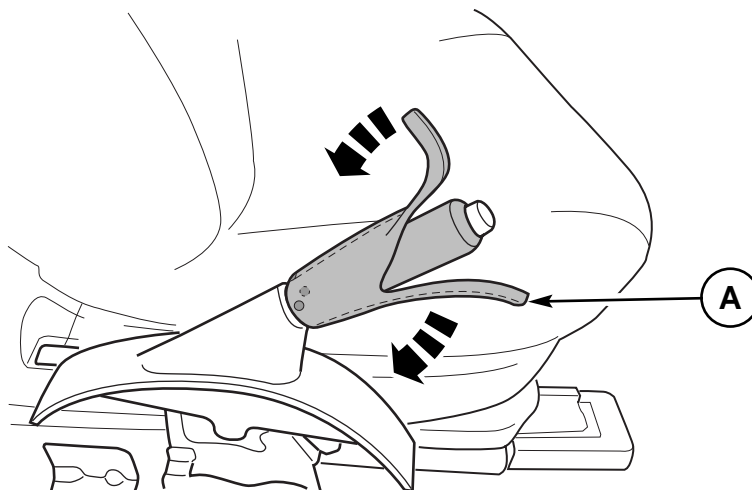

11

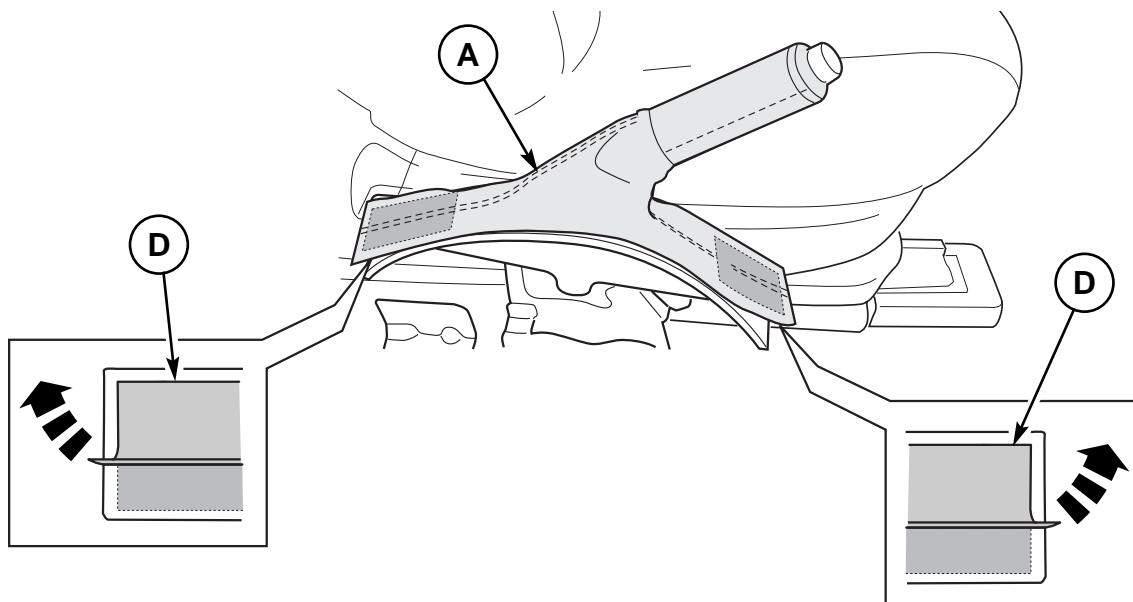

12

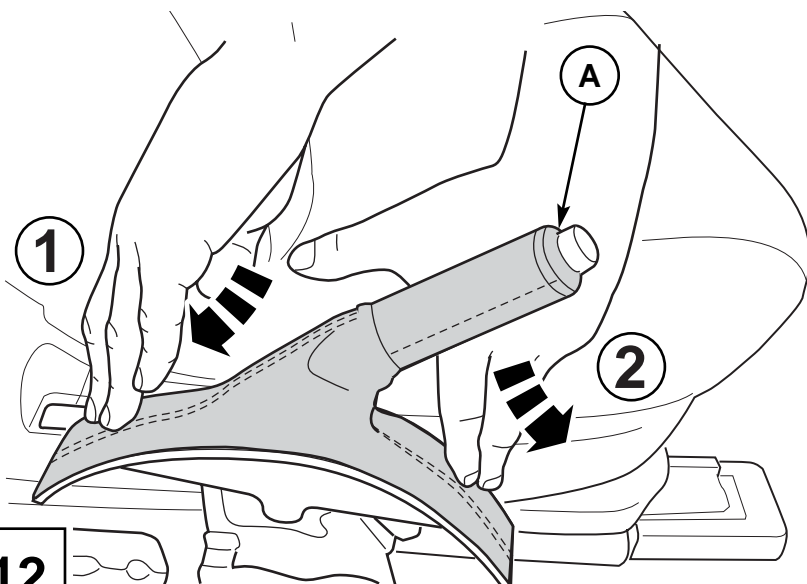

Subject to alteration without notice
 Technische Änderungen vorbehalten
 Reservadas modificaciones técnicas
 Sous réserve de modifications techniques
 Con riserva di apportare modifiche tecniche
 Reservamo-nos o direito a alterações técnicas
 Technische wijzigingen voorbehouden
 Med forbehold for tekniske ändringer
 Tekniske forendringer forbeholdes
 Med reservation för tekniska ändringar
 Tekniset muutokset pidätetään
 Technické zmeny vyhrazeny
 A változtatások technika jogát fenntartjuk
 Zmiany techniczne zastrzeżone
 Επιφυλασσόμεθα για αλλαγές